

ALUMINIUM COMPOSITE PANEL CLADDING SYSTEM

TYPICAL DETAILS

CONTENTS

1.0	TYPICAL VERTICAL JOINT ON RAB
1.1	TYPICAL VERTICAL JOINT ON BUILDING PAPER
2.0	TYPICAL HORIZONTAL JOINT ON RAB
2.1	TYPICAL HORIZONTAL JOINT ON BUILDING PAPER
3.1.0	HEAD DETAIL - FAIRVIEW RESIDENTIAL JOINERY
3.1.1	SILL DETAIL - FAIRVIEW RESIDENTIAL JOINERY
3.1.2	JAMB DETAIL - FAIRVIEW RESIDENTIAL JOINERY
3.2.0	HEAD DETAIL - FAIRVIEW COMMERCIAL JOINERY
3.2.1	SILL DETAIL - FAIRVIEW COMMERCIAL JOINERY
3.2.2	JAMB DETAIL - FAIRVIEW COMMERCIAL JOINERY
3.3.0	HEAD DETAIL - ALTUS RESIDENTIAL JOINERY
3.3.1	SILL DETAIL - ALTUS RESIDENTIAL JOINERY
3.3.2	JAMB DETAIL - ALTUS RESIDENTIAL JOINERY
3.4.0	HEAD DETAIL - ALTUS COMMERCIAL JOINERY
3.4.1	SILL DETAIL - ALTUS COMMERCIAL JOINERY
3.4.2	JAMB DETAIL - ALTUS COMMERCIAL JOINERY
3.5.0	HEAD DETAIL - APL RESIDENTIAL JOINERY
3.5.1	SILL DETAIL - APL RESIDENTIAL JOINERY
3.5.2	JAMB DETAIL - APL RESIDENTIAL JOINERY
3.6.0	HEAD DETAIL - APL COMMERCIAL JOINERY
3.6.1	SILL DETAIL - APL COMMERCIAL JOINERY
3.6.2	JAMB DETAIL - APL COMMERCIAL JOINERY
4.0	FASCIA DETAIL - SOFFIT BY OTHERS AT LOW WIND ZONE
4.1	FASCIA DETAIL - SOFFIT BY OTHERS AT HIGH WIND ZONE
4.2.0	FASCIA TO SOFFIT
4.2.1	FASCIA TO SOFFIT
4.3.0	DRIP EDGE DETAIL
4.3.1	OPEN FLUSH SOFFIT JOINT
5.0	BASE DETAIL 1
5.1	TYPICAL EYEBROW SILL DETAIL
5.2	TYPICAL UPSTAND DETAIL
5.3	INTER-STOREY JOINT
6.0.0	TYPICAL EXTERNAL CORNER
6.0.1	TYPICAL VERTICAL INTERNAL CORNER
6.1	FIBRE CEMENT VERTICAL INTERNAL CORNER
6.2	VERTICAL PROFILED METAL INTERNAL CORNER
6.3	HORIZONTAL PROFILED METAL INTERNAL CORNER
7.0	TYPICAL WALL TO SOFFIT JUNCTION 1
7.1	TYPICAL WALL TO SOFFIT BY JUNCTION 2
7.2.0	TYPICAL WALL TO RAKING SOFFIT JUNCTION 1
7.2.1	TYPICAL WALL TO RAKING SOFFIT JUNCTION 2
7.3	WALL TO SOFFIT JUNCTION & DOWNPIPE PENETRATION
8.0	PRECAST CONCRETE WALL JUNCTION 1
8.1	PRECAST CONCRETE WALL JUNCTION 2
9.0	VERTICAL PROFILED METAL JUNCTION

ALUMINIUM COMPOSITE PANEL CLADDING SYSTEM

NOTES

General notes:

1. Consider 'hatched' areas as outside of THE BUILDING AGENCY scope and indicative only.
2. All commercial detailing shows rigid air barrier (RAB) as is common practice.
3. All residential detailing shows building wrap as is common practice.

Framing note: Timber framing by others is to be at 600 centres max for both studs & nogs. This may be required at closer centers subject to engineering requirements.

Rigid air barrier note: As per THE BUILDING AGENCY BRANZ Appraisal #528.## section 12.2 "A building with exposure to wind on any part of its facade above 1.55 kPa ULS must use a RAB as backing for the cavity". It is the building designers responsibility to determine wind loading on the building and incorporate RAB into the detailing as required to the specifications of the RAB manufacturer.

Cavity Battens are not required with the THE BUILDING AGENCY cladding system as a cavity is formed between the fixing angles and structure with high impact plastic packers ("H" packers). Minimum cavity depth is 40mm from structure to outer face of panel although experience shows the cavity is normally 50mm or more. Any instance where cavity is pushed beyond 60mm may require the installation of 20mm cavity battens by others.

ALUMINIUM COMPOSITE PANEL CLADDING SYSTEM

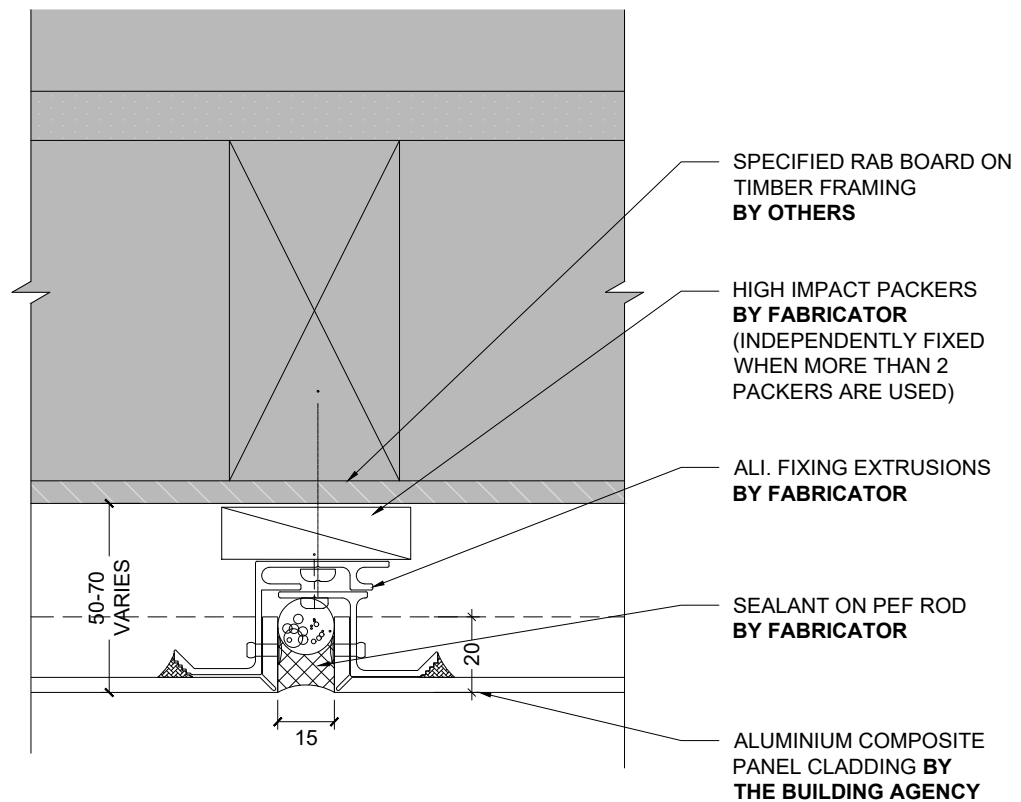

1 TYPICAL VERTICAL JOINT ON RAB (PLAN)
 - 1:2 @ A4

NOTE: TIMBER FRAMING BY OTHERS TO BE AT 600 CTRS MAX FOR BOTH STUDS & NOGS. MAY BE REQUIRED AT CLOSER CENTERS SUBJECT TO ENGINEERING REQUIREMENTS

ALUMINIUM COMPOSITE PANEL CLADDING SYSTEM

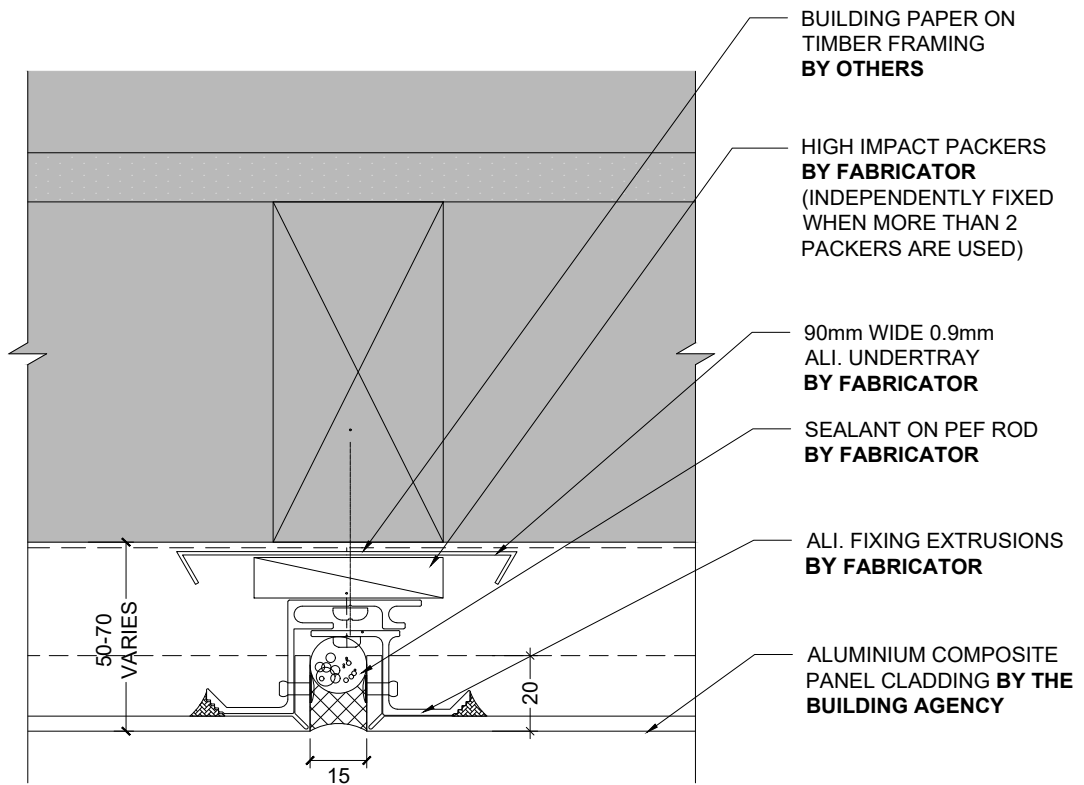

1 TYPICAL VERTICAL JOINT ON BUILDING PAPER (PLAN)
- 1:2 @ A4

NOTE: TIMBER FRAMING BY OTHERS TO BE AT 600 CTRS MAX FOR BOTH STUDS & NOGS. MAY BE REQUIRED AT CLOSER CENTERS SUBJECT TO ENGINEERING REQUIREMENTS

ALUMINIUM COMPOSITE PANEL CLADDING SYSTEM

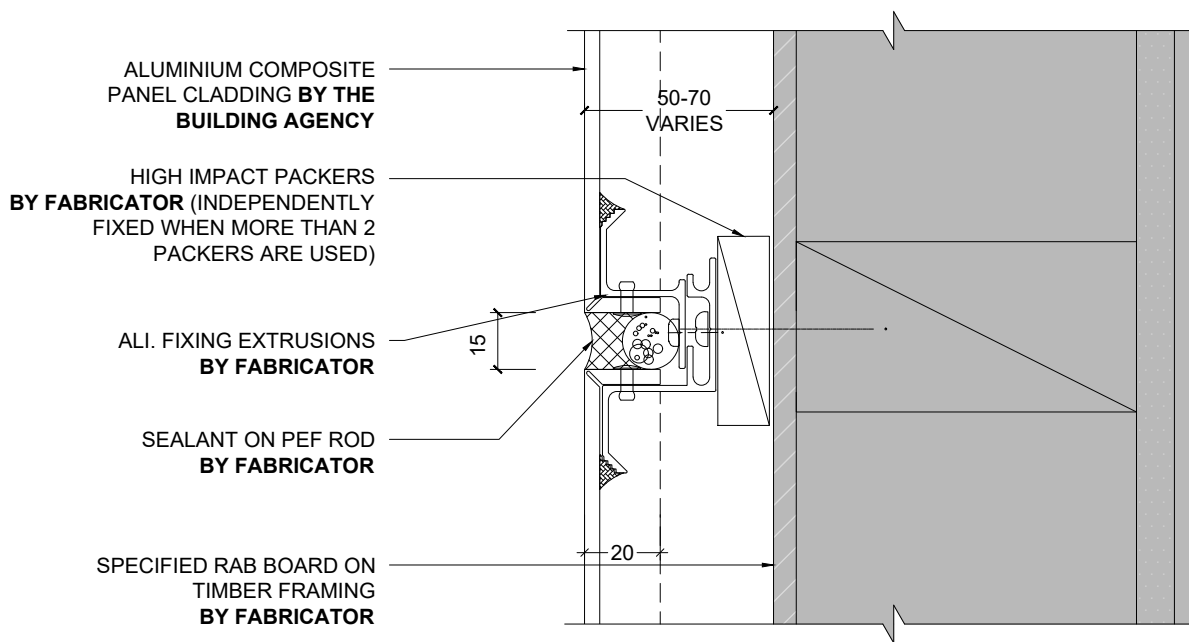

1 TYPICAL HORIZONTAL JOINT ON RAB (SECTION)
1:2 @ A4

NOTE: TIMBER FRAMING BY OTHERS TO BE AT 600 CTRS MAX FOR BOTH STUDS & NOGS. MAY BE REQUIRED AT CLOSER CENTERS SUBJECT TO ENGINEERING REQUIREMENTS

ALUMINIUM COMPOSITE PANEL CLADDING SYSTEM

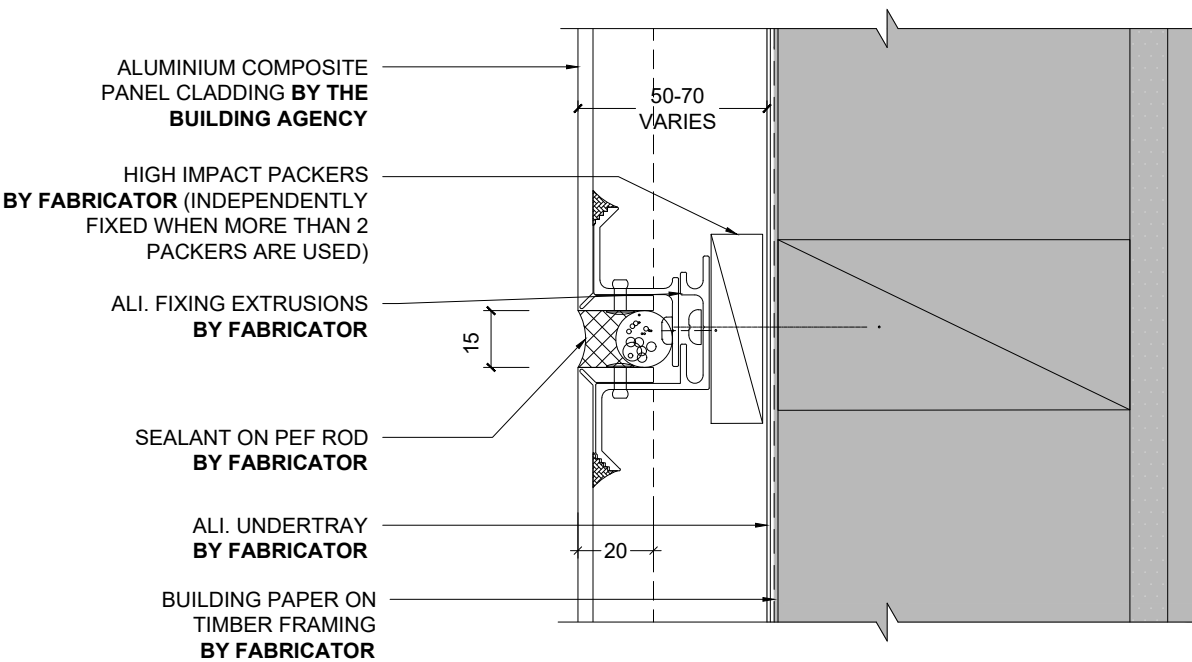

1 TYPICAL HORIZONTAL JOINT ON BUILDING PAPER (SECTION DETAIL)
1:2 @ A4

NOTE: TIMBER FRAMING BY OTHERS TO BE AT 600 CTRS MAX FOR BOTH STUDS & NOGS. MAY BE REQUIRED AT CLOSER CENTERS SUBJECT TO ENGINEERING REQUIREMENTS

ALUMINIUM COMPOSITE PANEL CLADDING SYSTEM

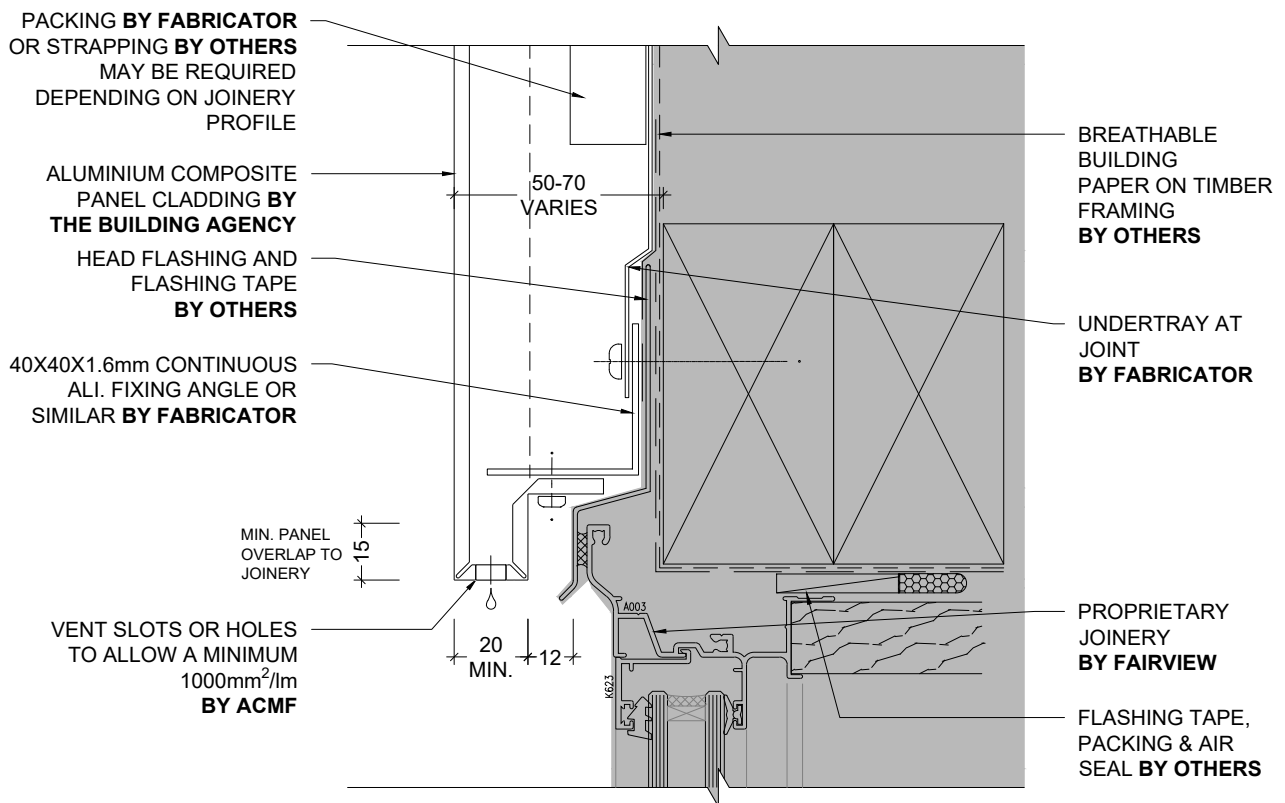

1 HEAD DETAIL - FAIRVIEW RESIDENTIAL JOINERY (SECTION)
1:2 @ A4

ALUMINIUM COMPOSITE PANEL CLADDING SYSTEM

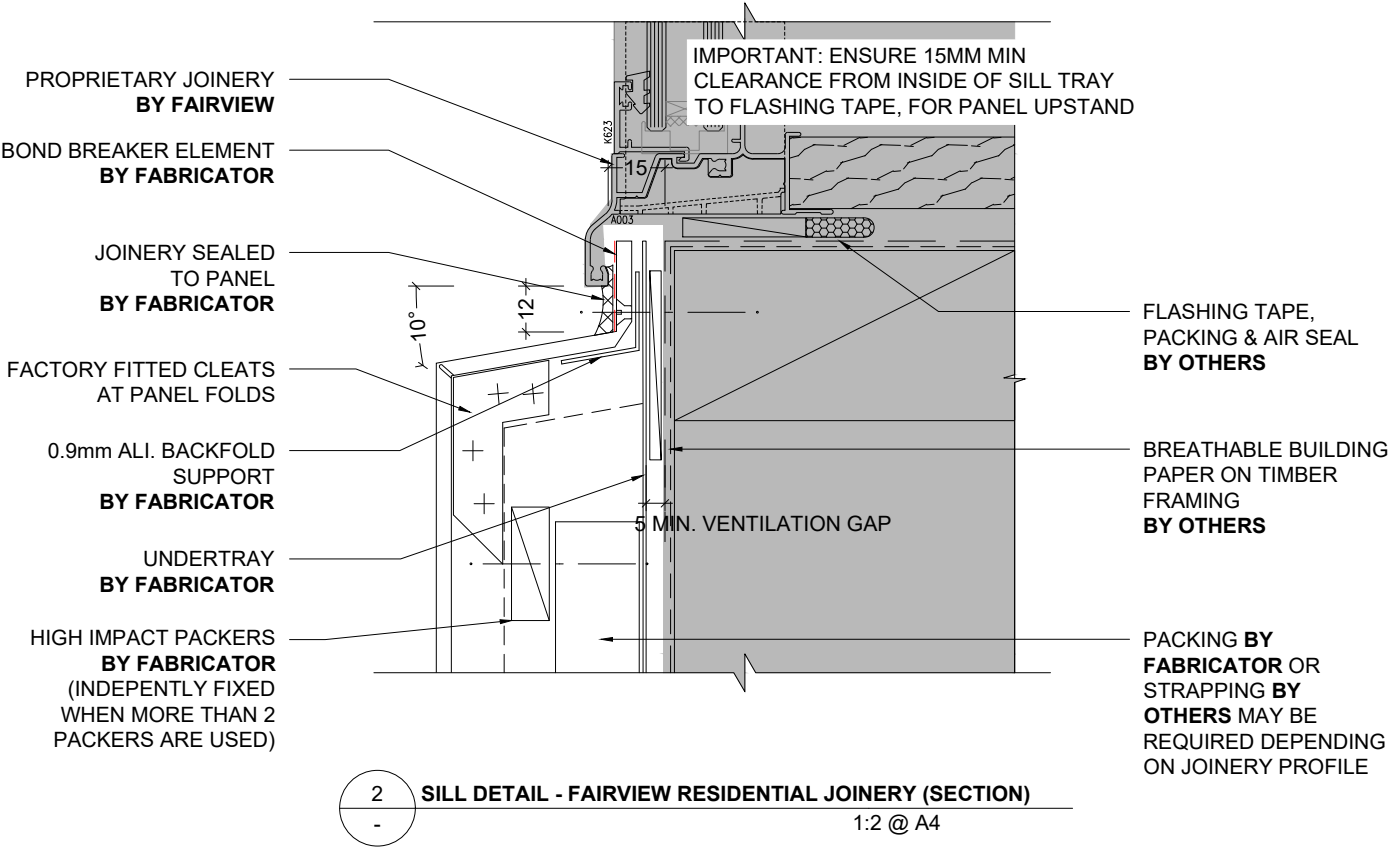

ALUMINIUM COMPOSITE PANEL CLADDING SYSTEM

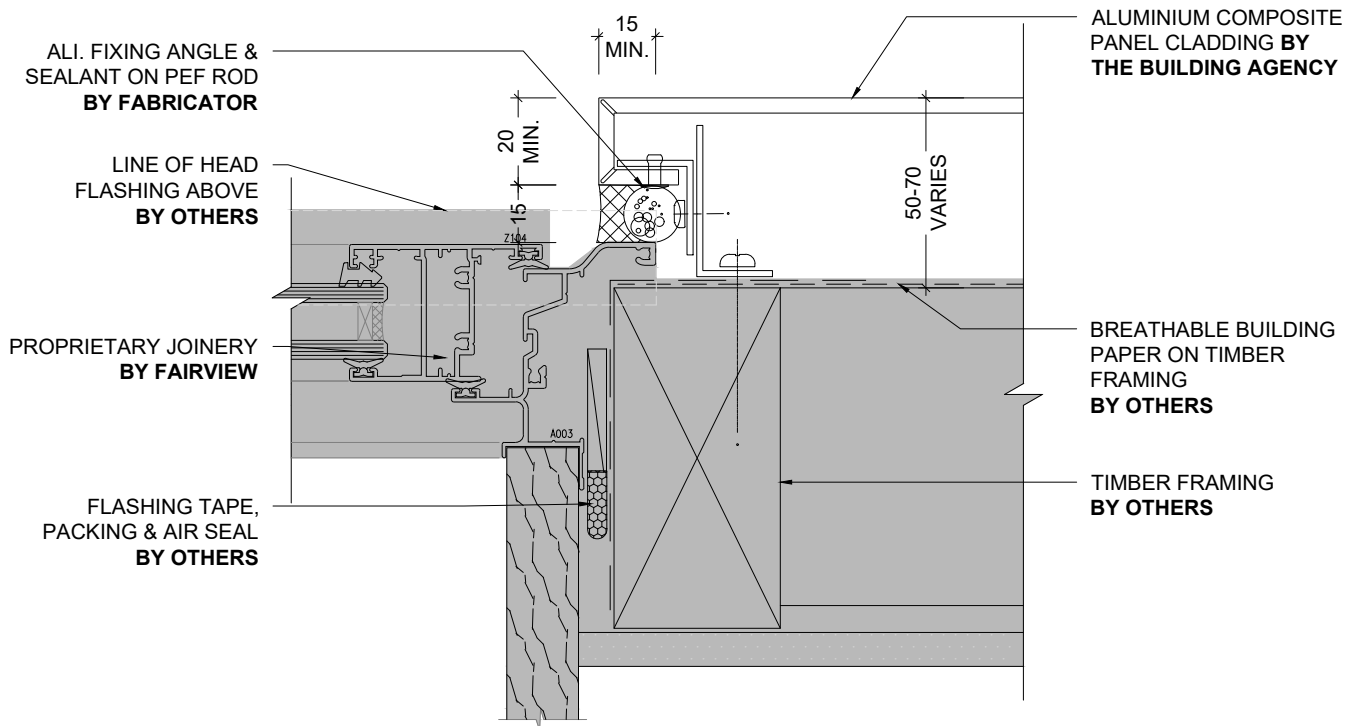

1 JAMB DETAIL - FAIRVIEW RESIDENTIAL JOINERY (PLAN)
- 1:2 @ A4

ALUMINIUM COMPOSITE PANEL CLADDING SYSTEM

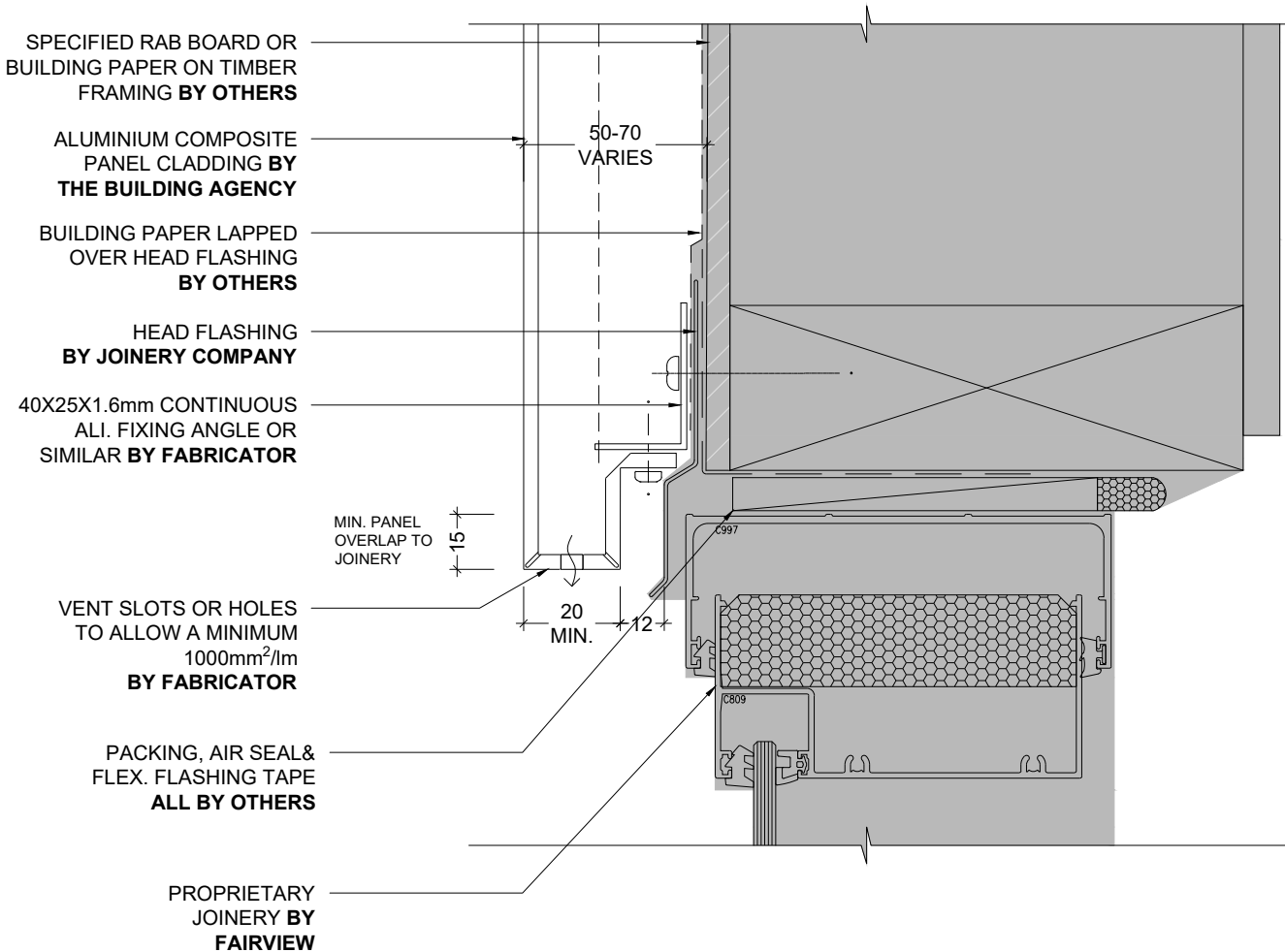

1 TYPICAL FAIRVIEW COMMERCIAL HEAD DETAIL (SECTION)
- 1:2 @ A4

ALUMINIUM COMPOSITE PANEL CLADDING SYSTEM

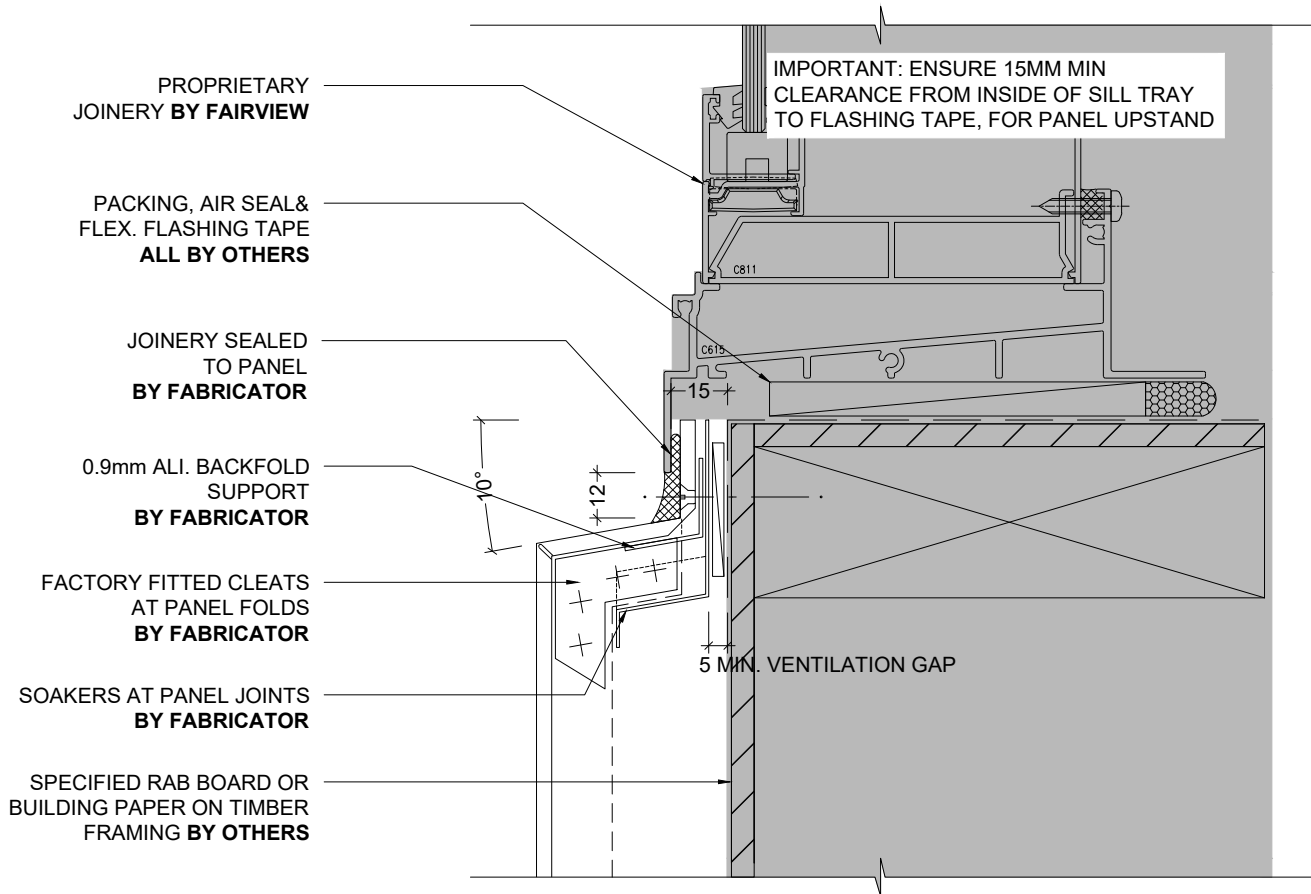

2 TYPICAL FAIRVIEW COMMERCIAL SILL DETAIL (SECTION)
- 1:2 @ A4

ALUMINIUM COMPOSITE PANEL CLADDING SYSTEM

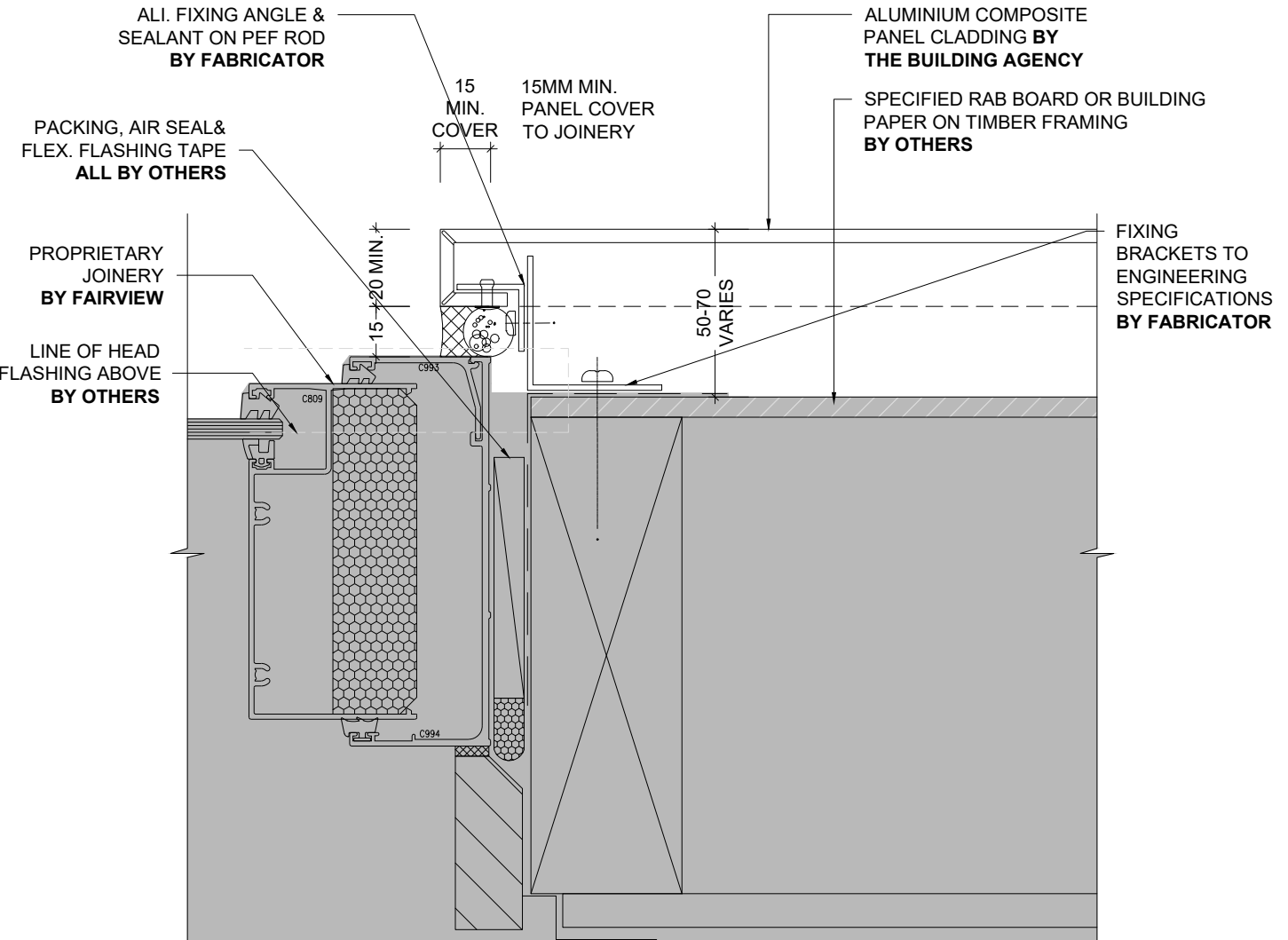

1 TYPICAL FAIRVIEW COMMERCIAL JAMB DETAIL (PLAN)
- 1:2 @ A4

ALUMINIUM COMPOSITE PANEL CLADDING SYSTEM

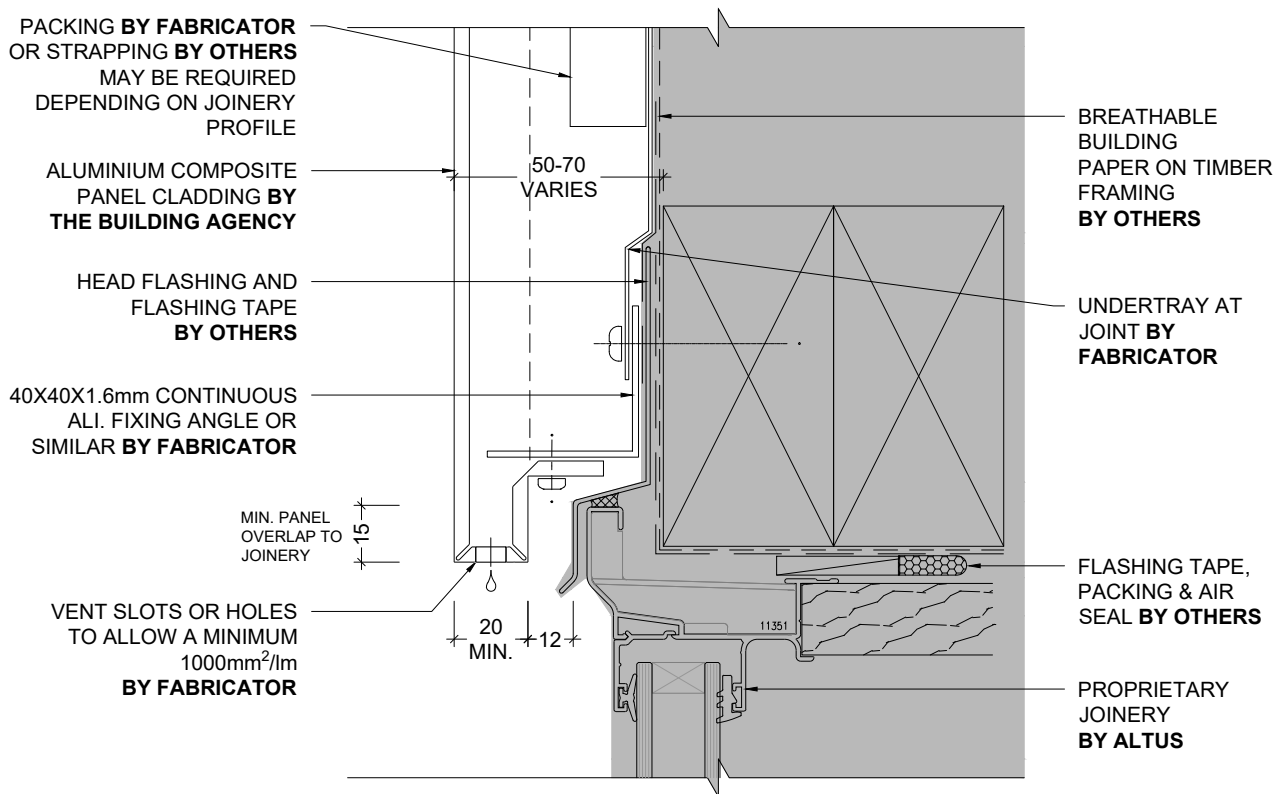

1 HEAD DETAIL - ALTUS RESIDENTIAL JOINERY (SECTION)
 1:2 @ A4

ALUMINIUM COMPOSITE PANEL CLADDING SYSTEM

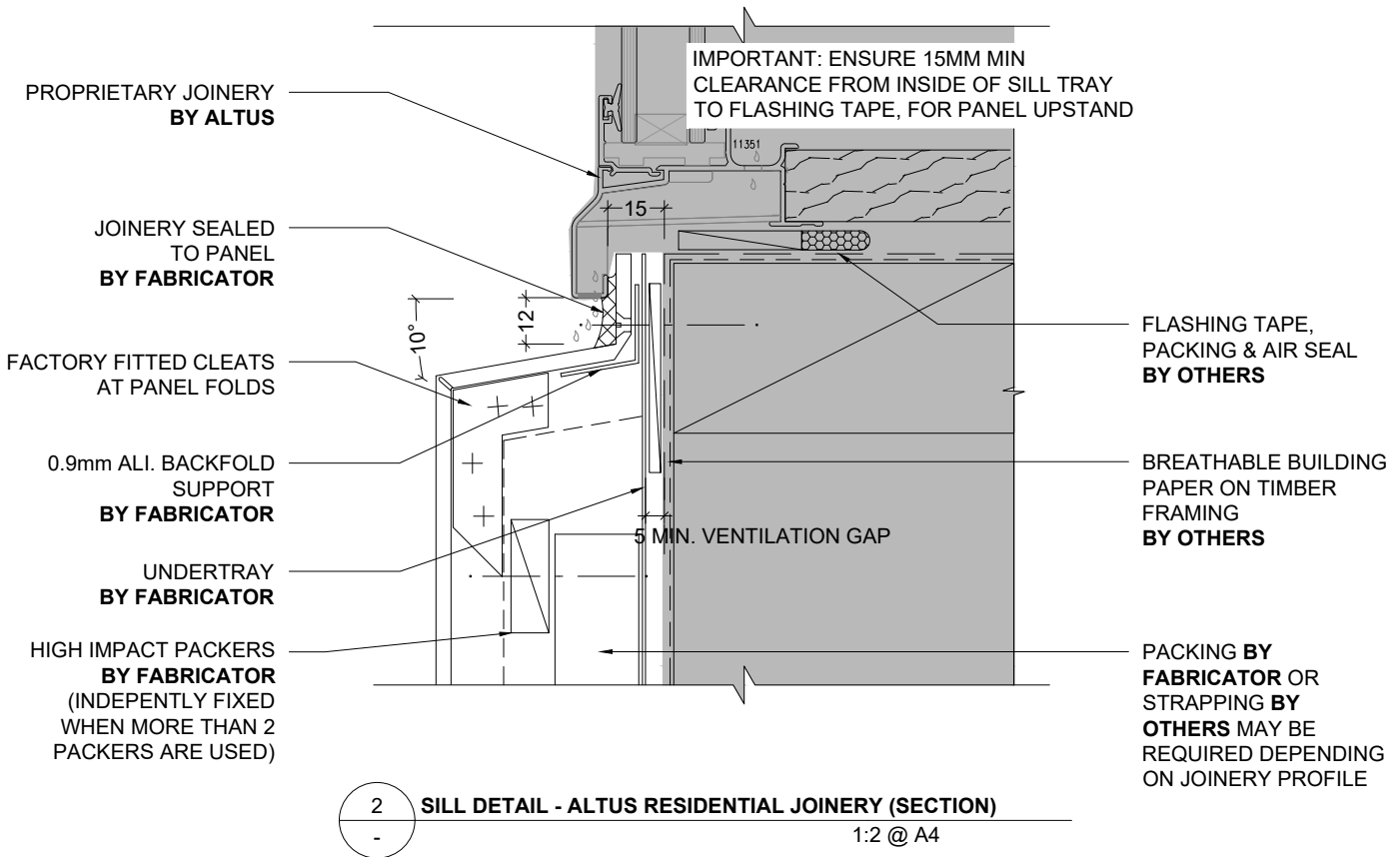

ALUMINIUM COMPOSITE PANEL CLADDING SYSTEM

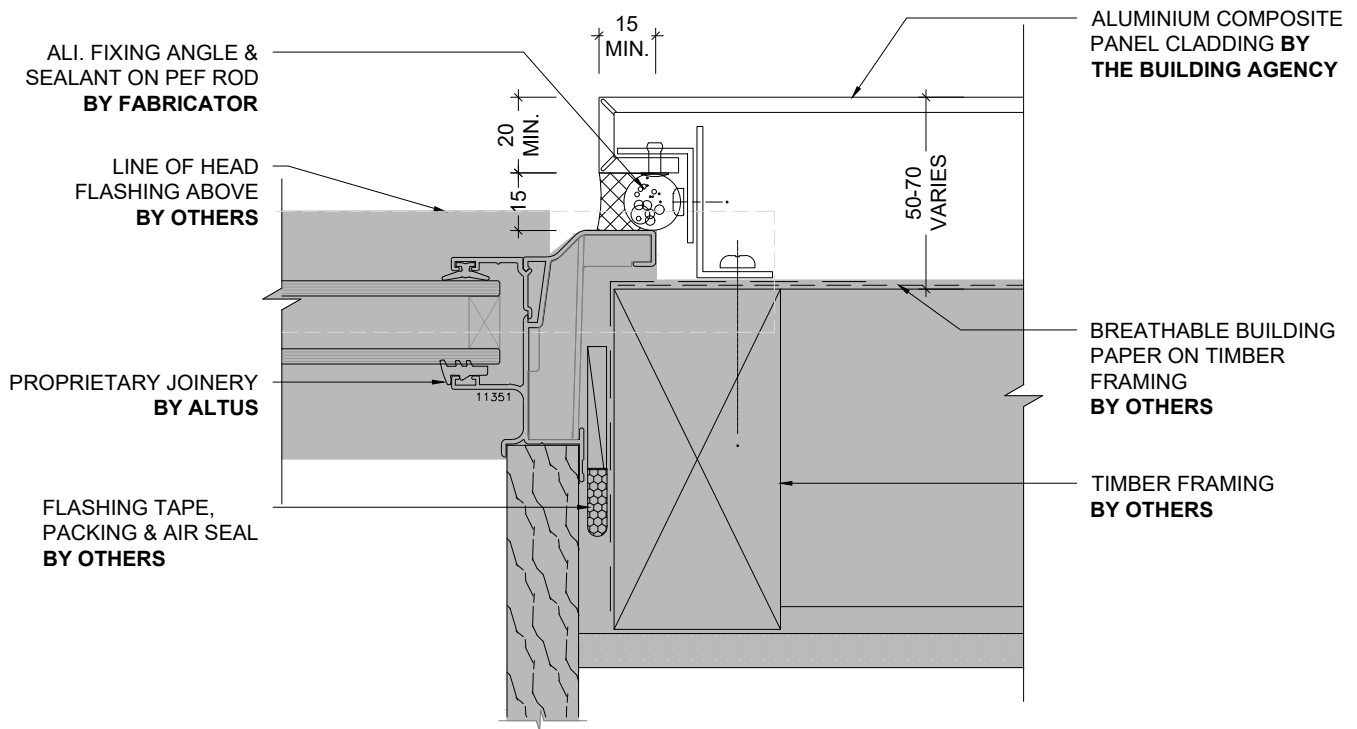

1 JAMB DETAIL - ALTUS RESIDENTIAL JOINERY (PLAN)
- 1:2 @ A4

ALUMINIUM COMPOSITE PANEL CLADDING SYSTEM

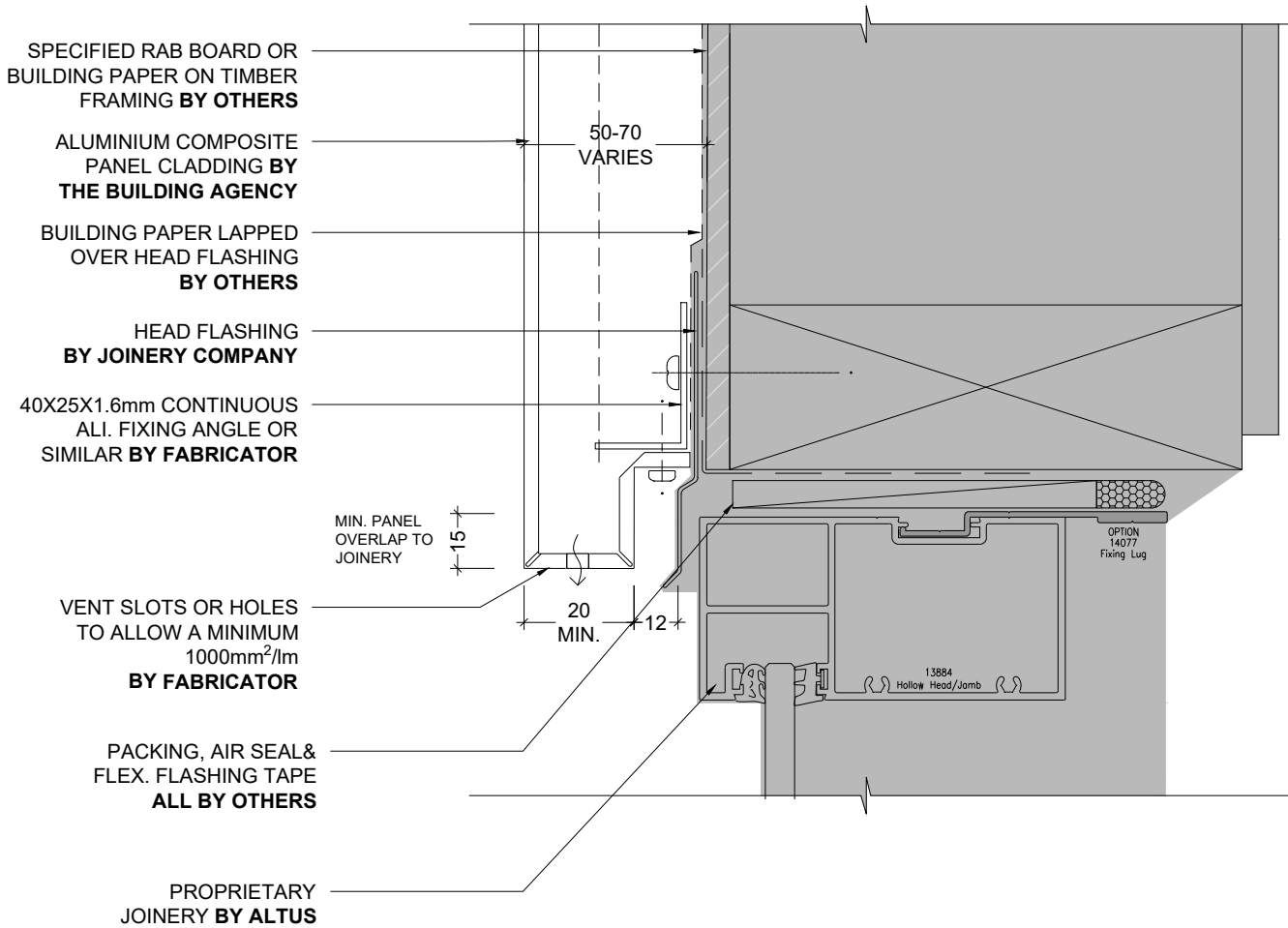

1 TYPICAL ALTUS COMMERCIAL HEAD DETAIL (SECTION)
1:2 @ A4

ALUMINIUM COMPOSITE PANEL CLADDING SYSTEM

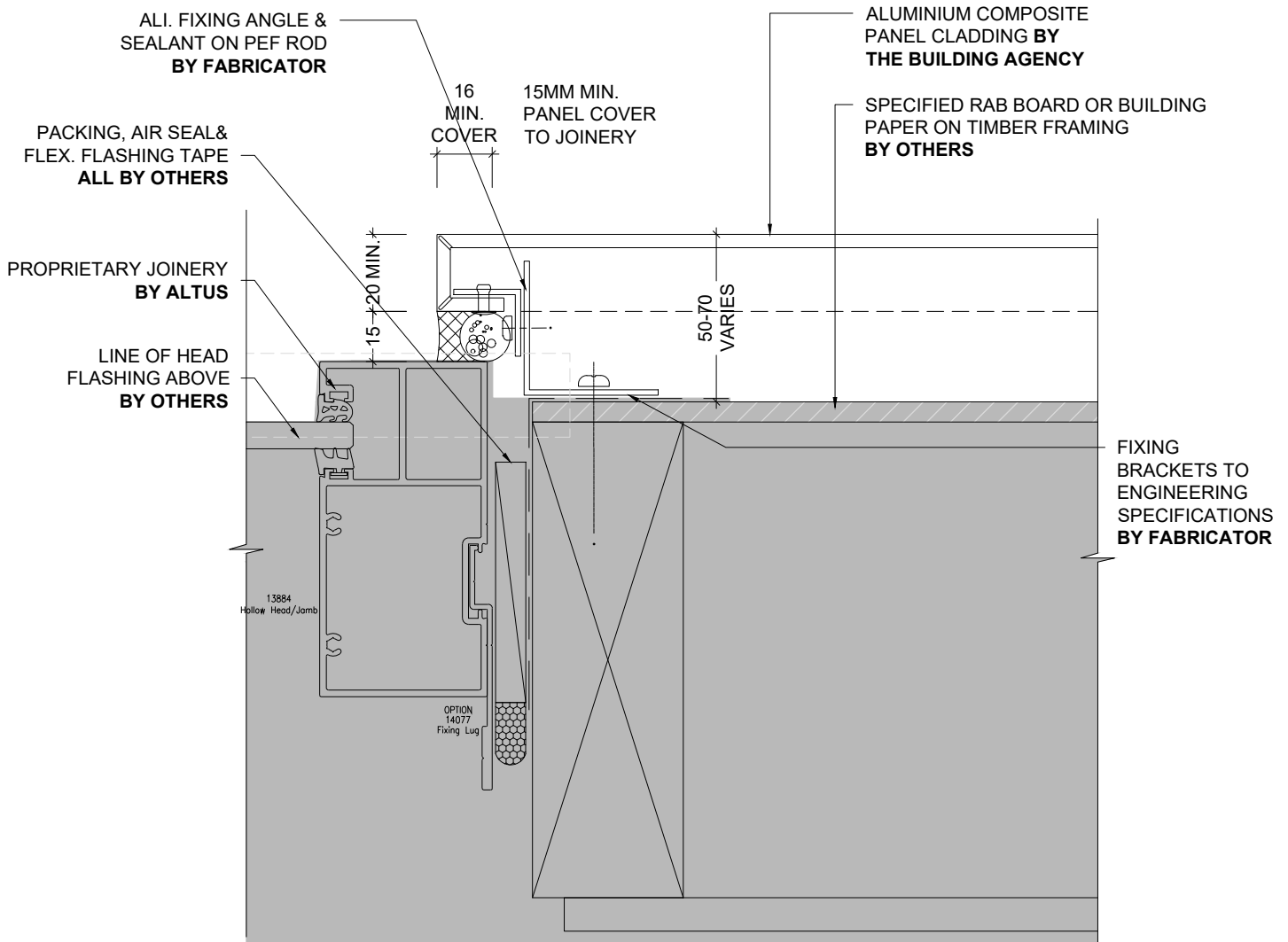

1 TYPICAL ALTUS COMMERCIAL JAMB DETAIL (PLAN) 1:2 @ A4

ALUMINIUM COMPOSITE PANEL CLADDING SYSTEM

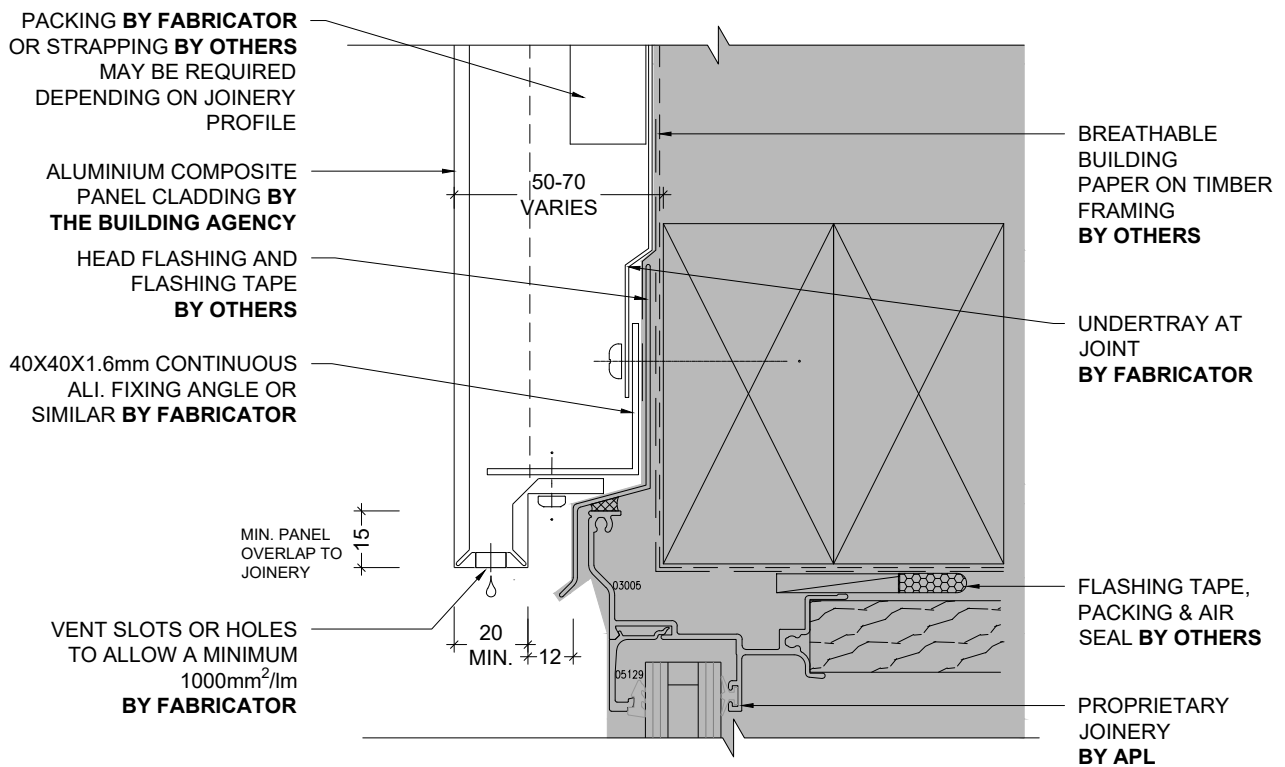

1 HEAD DETAIL - APL RESIDENTIAL JOINERY (SECTION) 1:2 @ A4

ALUMINIUM COMPOSITE PANEL CLADDING SYSTEM

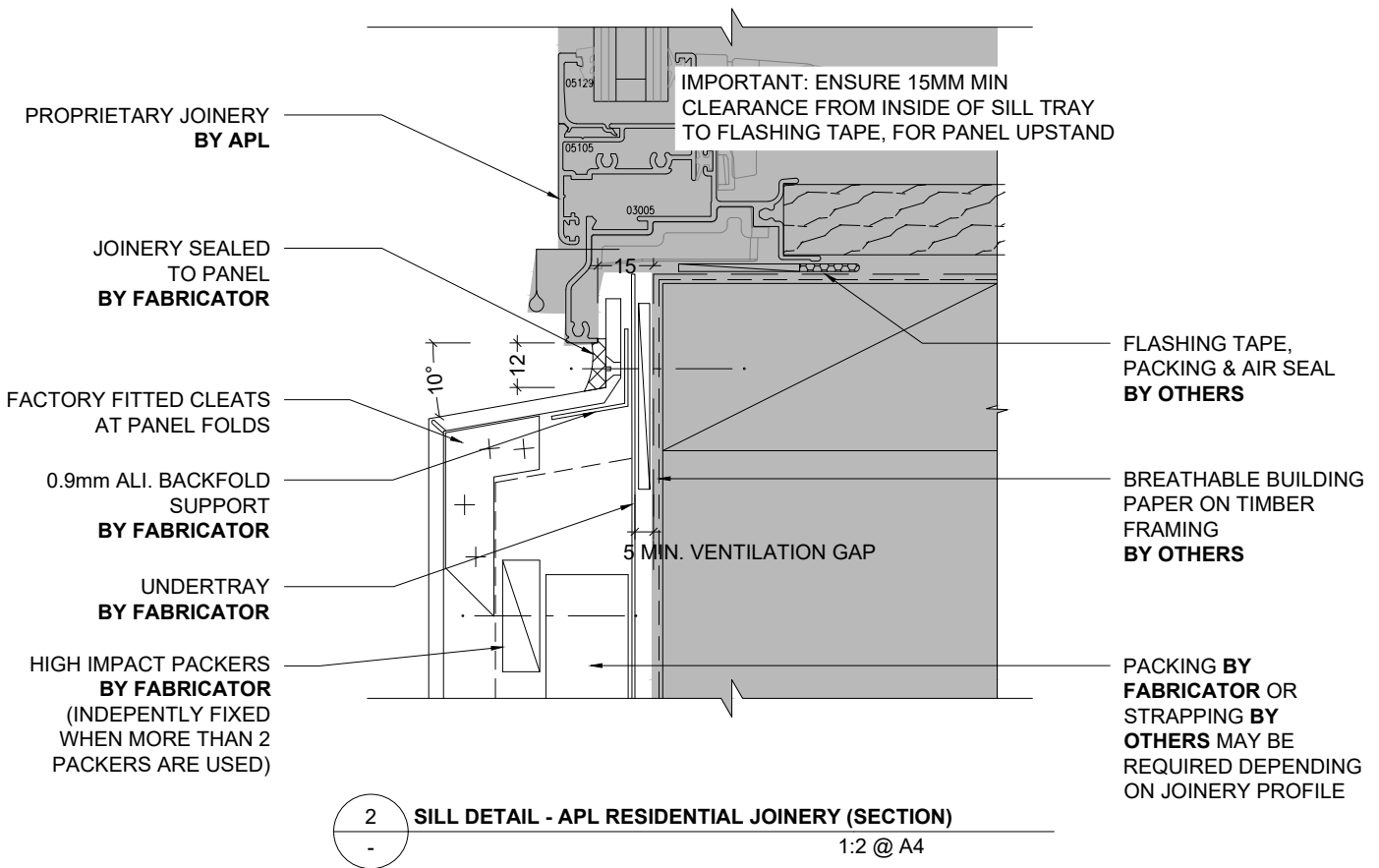

ALUMINIUM COMPOSITE PANEL CLADDING SYSTEM

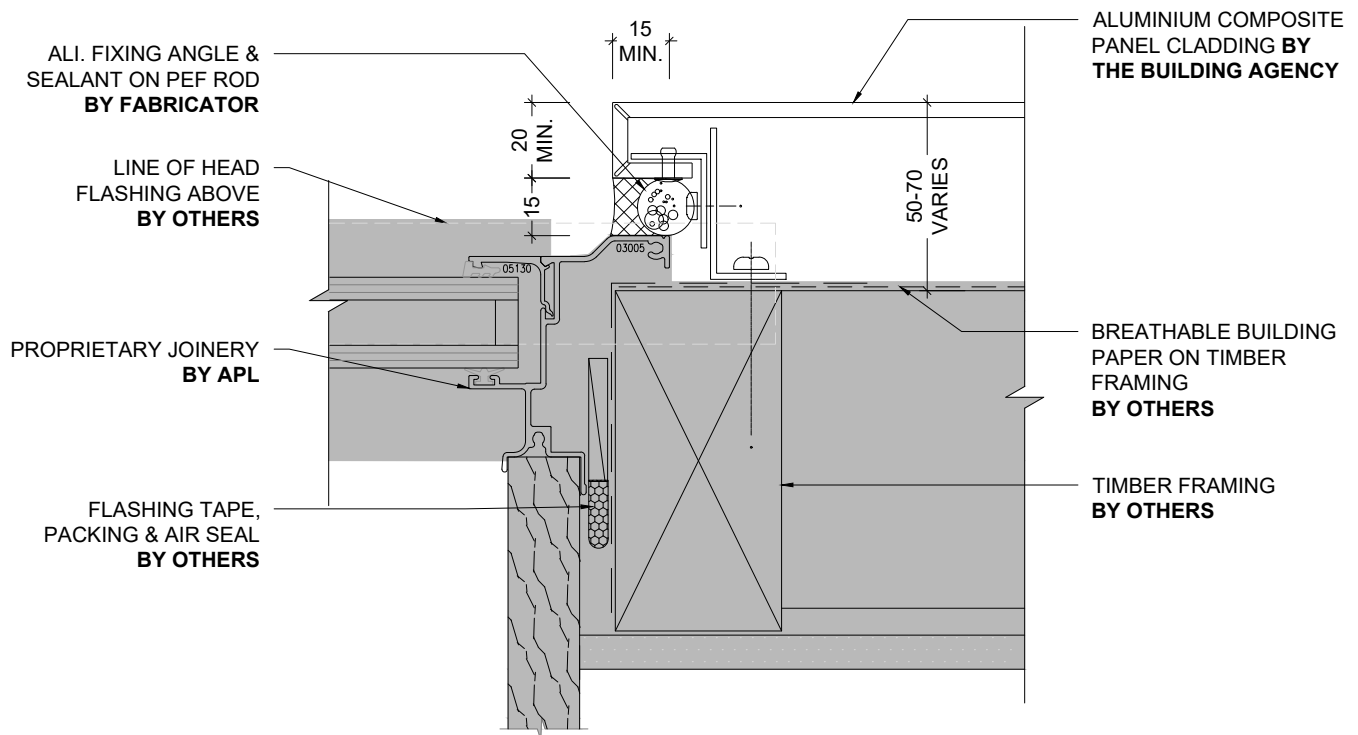

1 JAMB DETAIL - APL RESIDENTIAL JOINERY (PLAN)
- 1:2 @ A4

ALUMINIUM COMPOSITE PANEL CLADDING SYSTEM

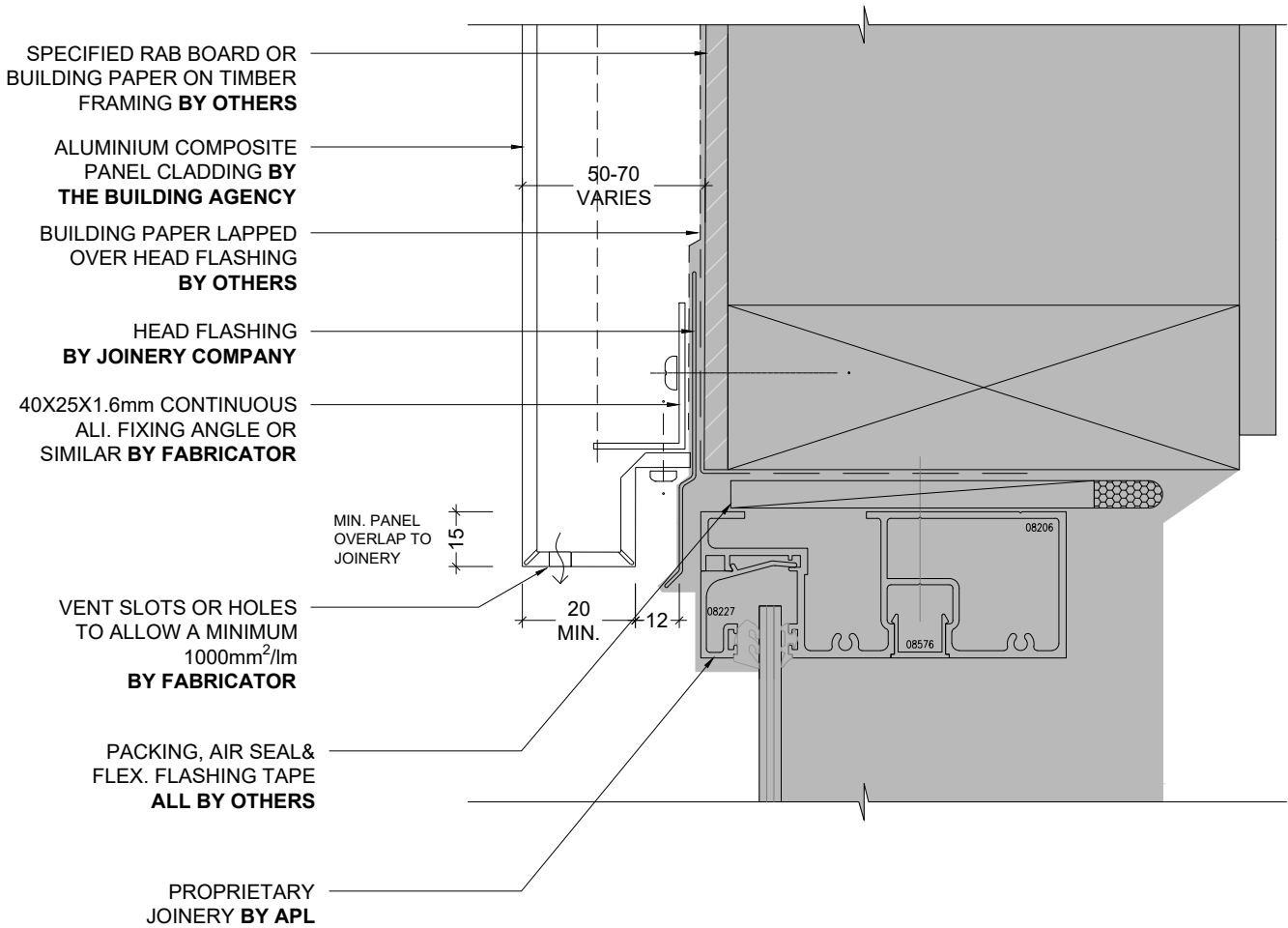

1 TYPICAL APL COMMERCIAL HEAD DETAIL (SECTION)
-
1:2 @ A4

ALUMINIUM COMPOSITE PANEL CLADDING SYSTEM

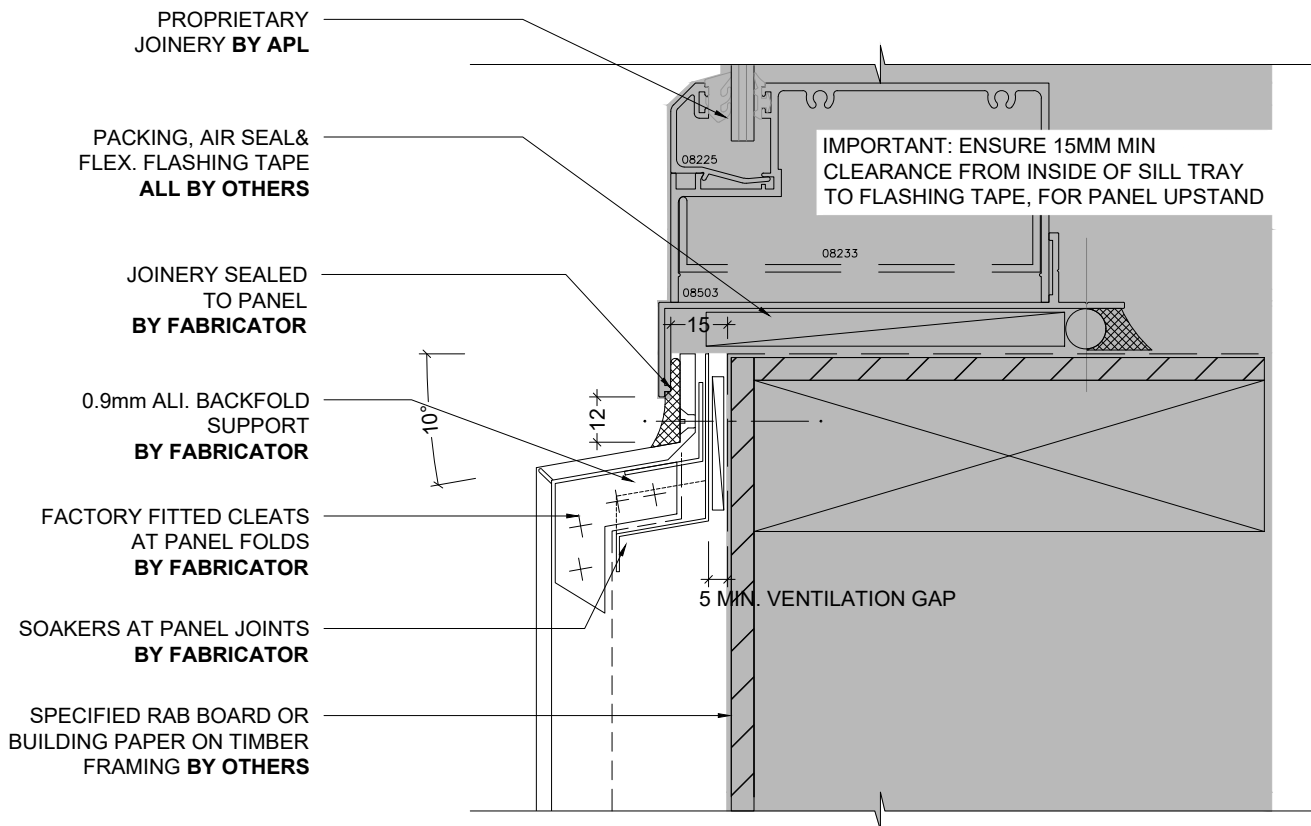

2 TYPICAL APL COMMERCIAL SILL DETAIL (SECTION)
- 1:2 @ A4

ALUMINIUM COMPOSITE PANEL CLADDING SYSTEM

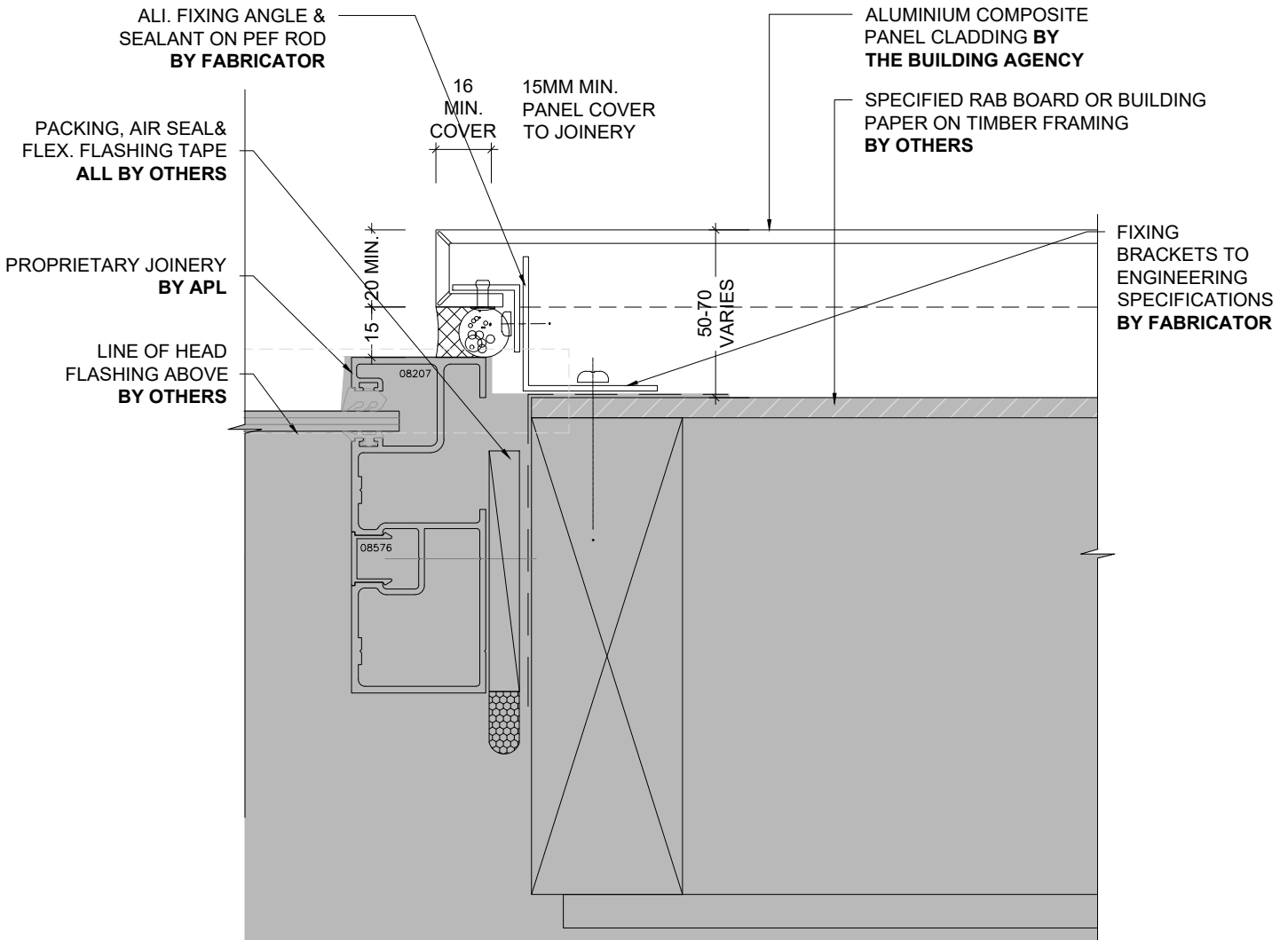

1 TYPICAL APL COMMERCIAL JAMB DETAIL (PLAN)
- 1:2 @ A4

ALUMINIUM COMPOSITE PANEL CLADDING SYSTEM

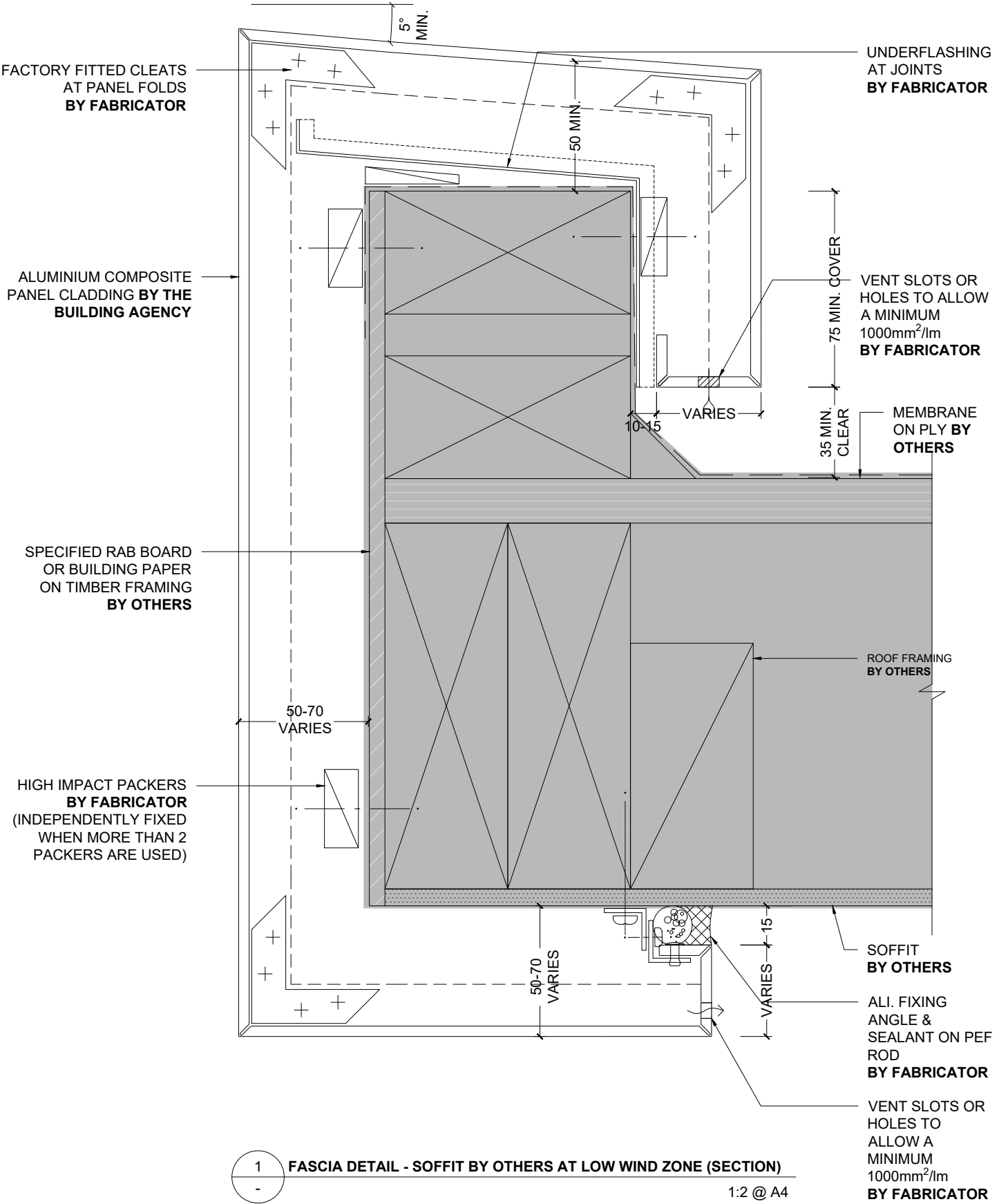

ALUMINIUM COMPOSITE PANEL CLADDING SYSTEM

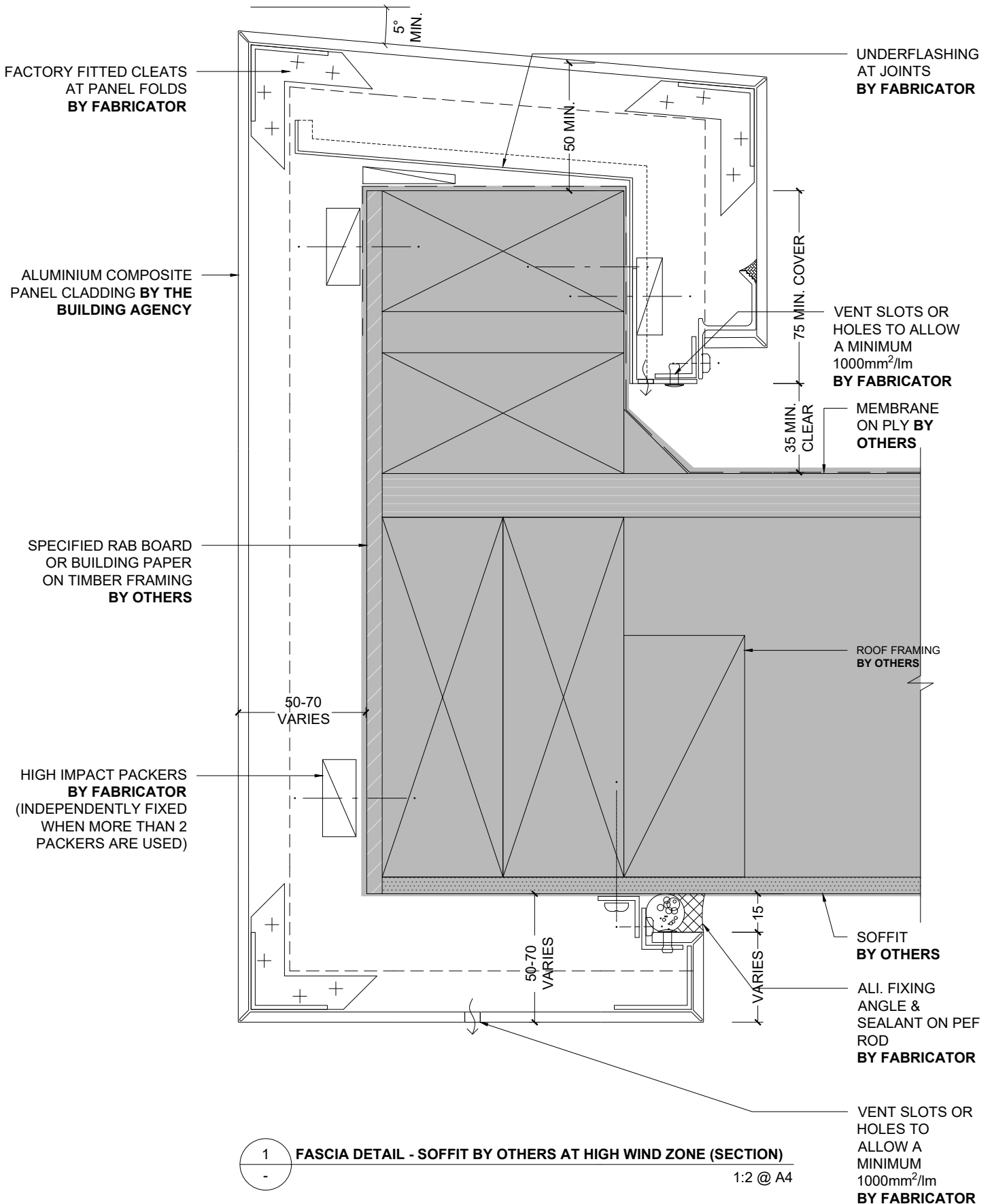

ALUMINIUM COMPOSITE PANEL CLADDING SYSTEM

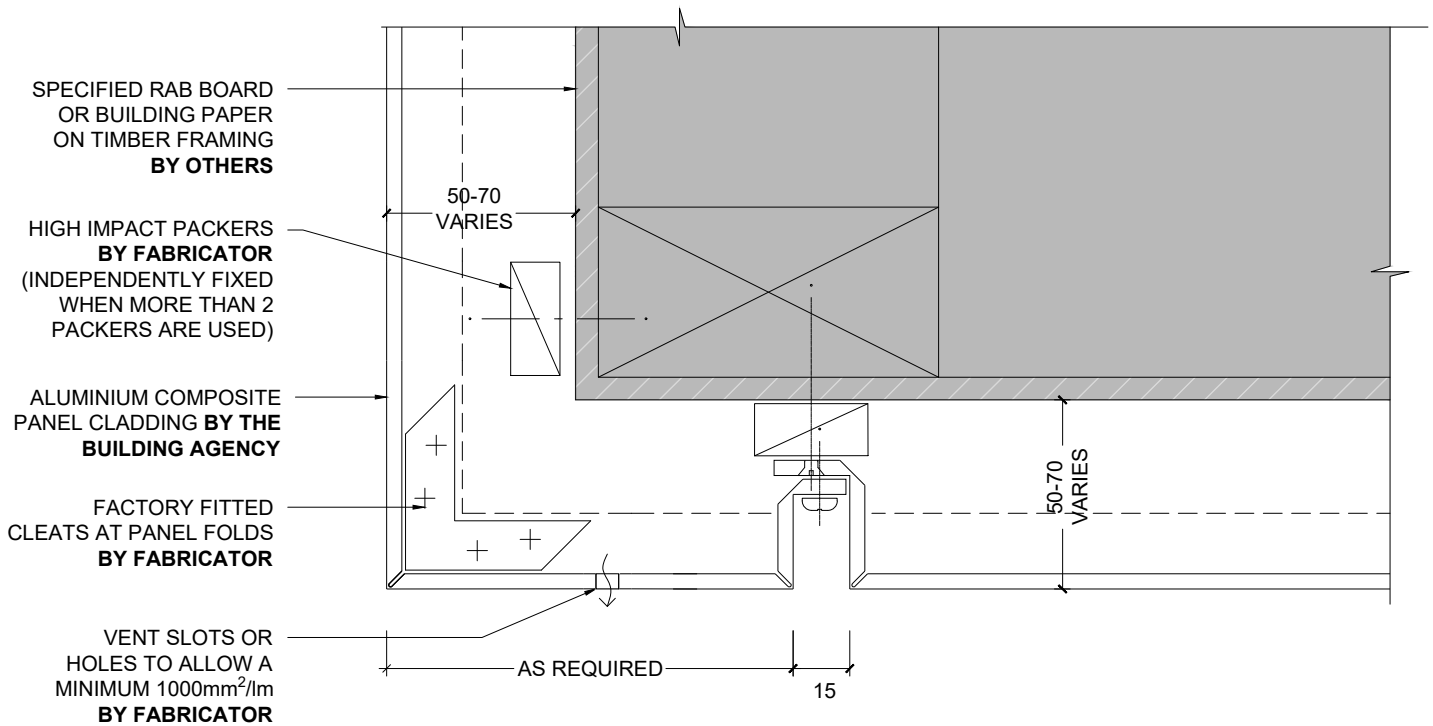

1 SOLID ALUMINIUM FASCIA TO SOFFIT 1 (SECTION)
- 1:2 @ A4

ALUMINIUM COMPOSITE PANEL CLADDING SYSTEM

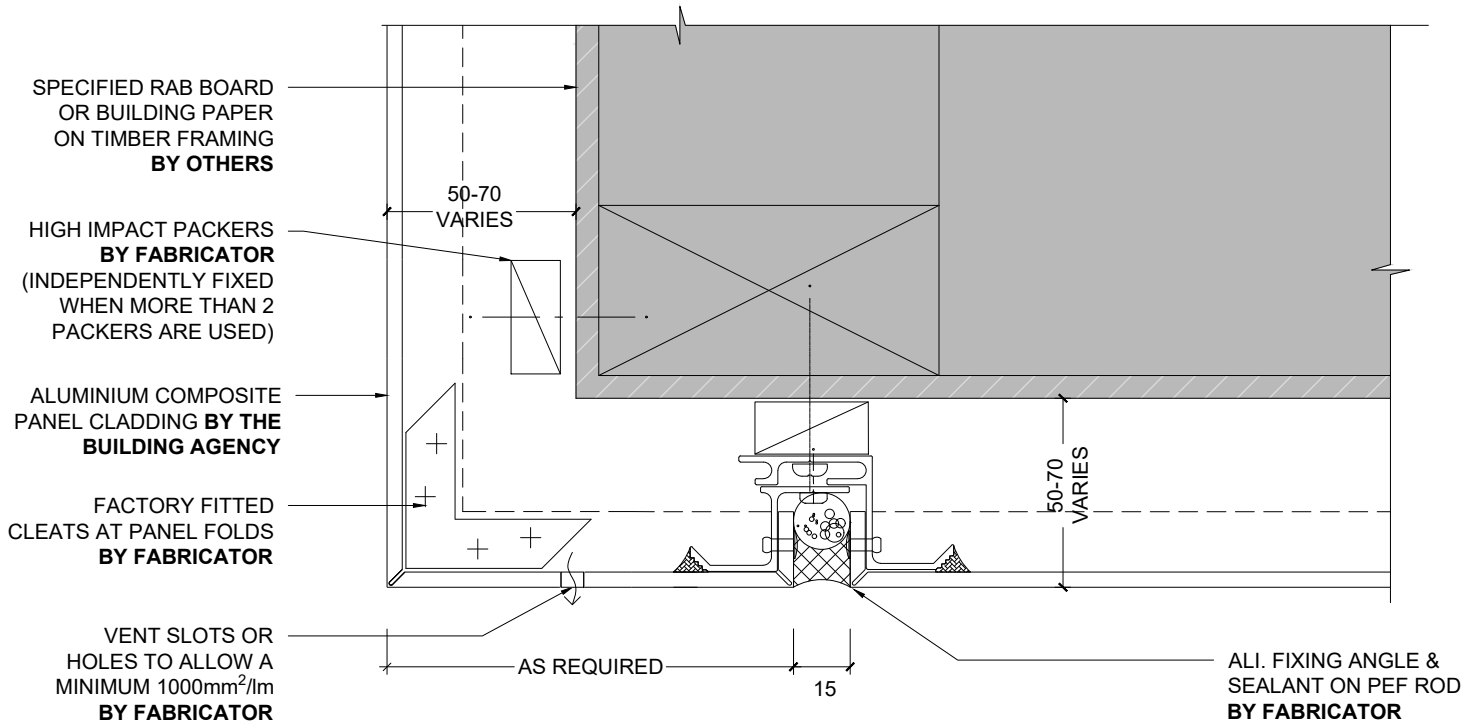

2 SOLID ALUMINIUM FASCIA TO SOFFIT 2 (SECTION)
- 1:2 @ A4

ALUMINIUM COMPOSITE PANEL CLADDING SYSTEM

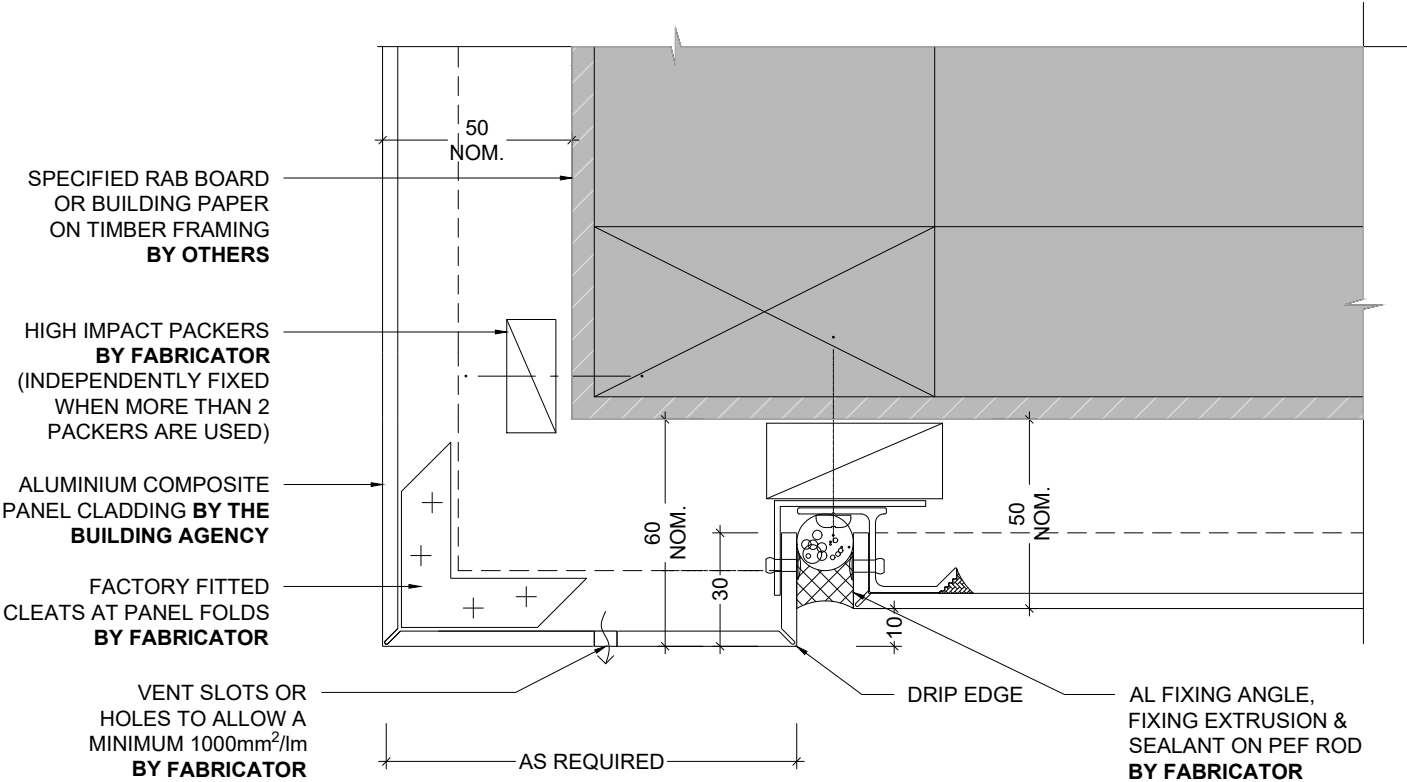

1 DRIP EDGE DETAIL (SECTION)

1:2 @ A4

ALUMINIUM COMPOSITE PANEL CLADDING SYSTEM

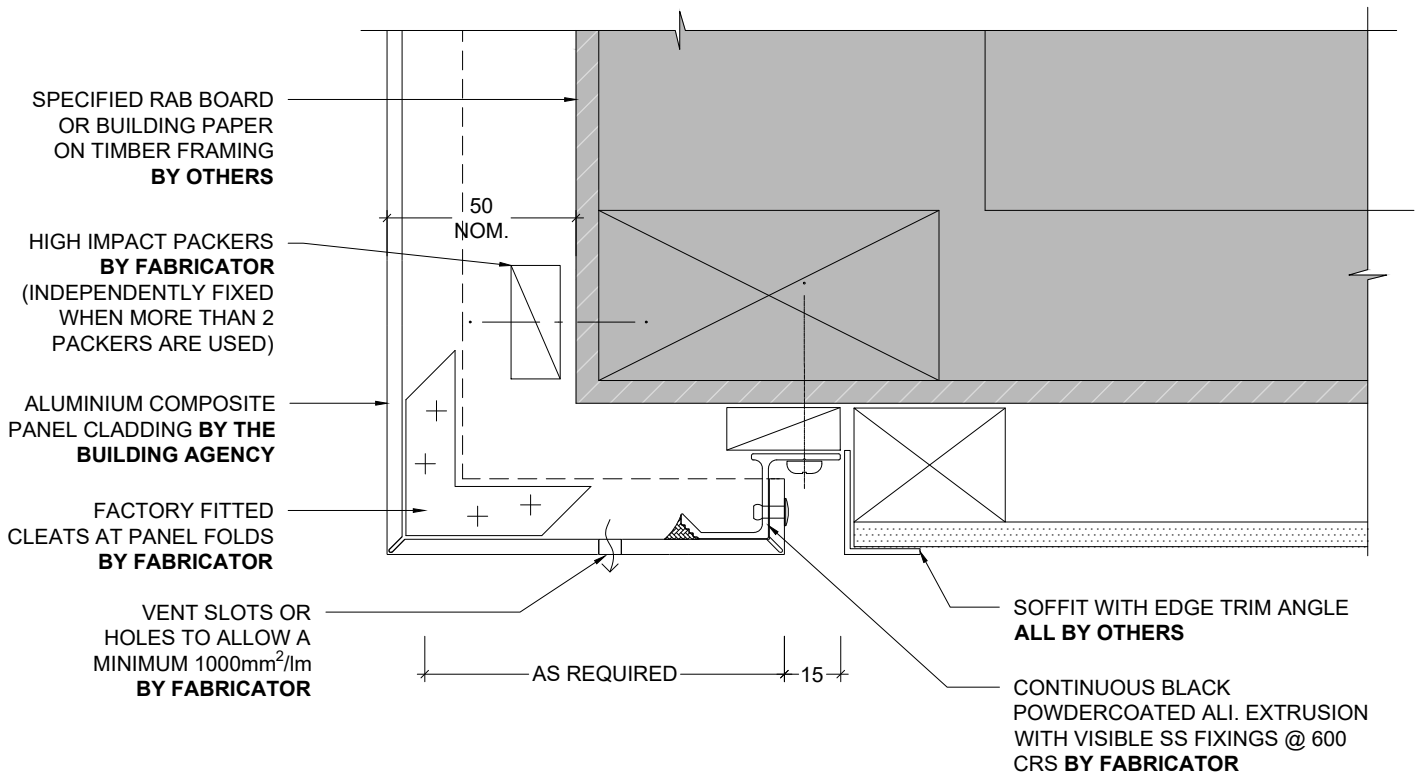

1 OPEN FLUSH SOFFIT JOINT (SECTION)
- 1:2 @ A4

ALUMINIUM COMPOSITE PANEL CLADDING SYSTEM

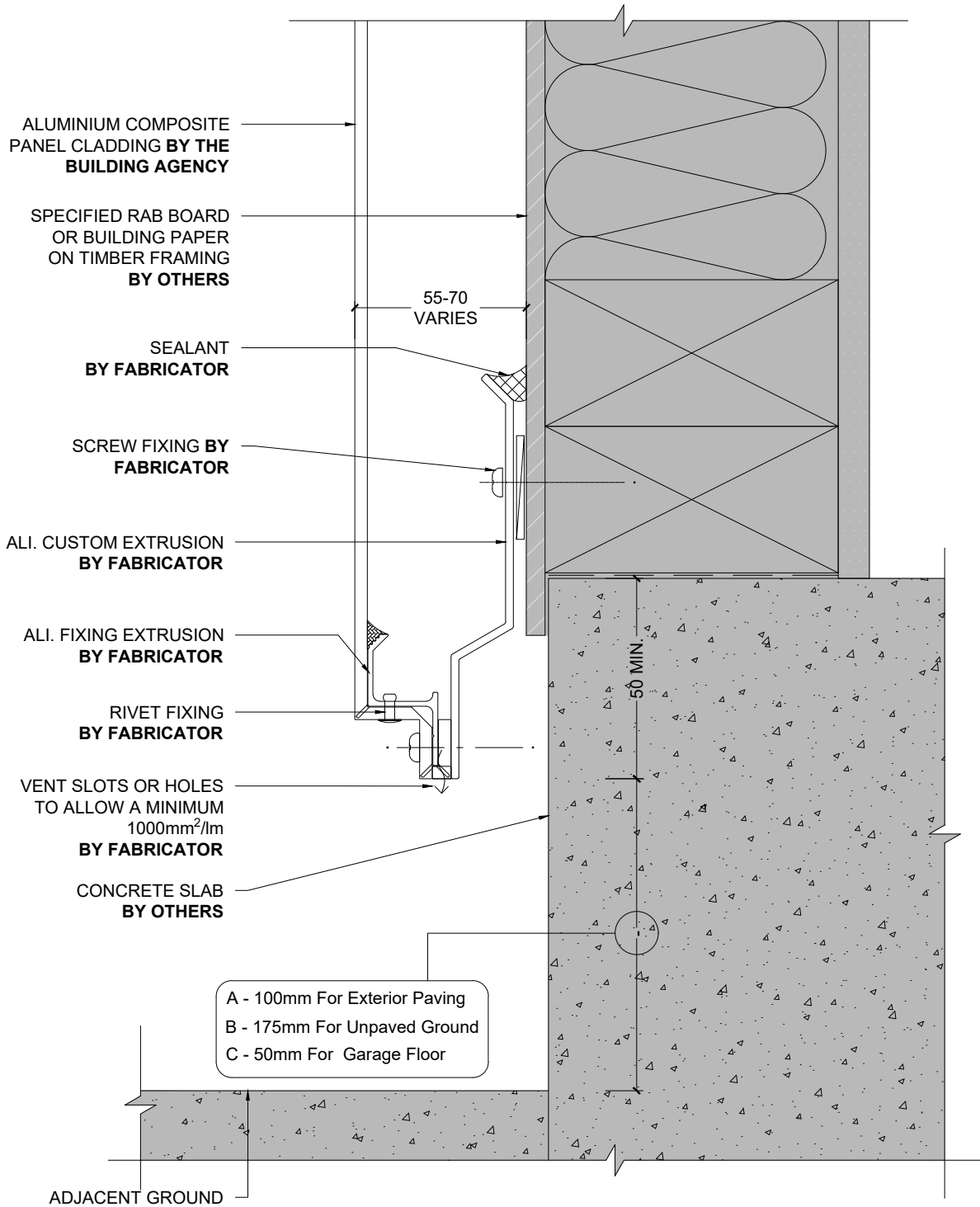

1 BASE DETAIL 1 (SECTION)
-
1:2 @ A4

ALUMINIUM COMPOSITE PANEL CLADDING SYSTEM

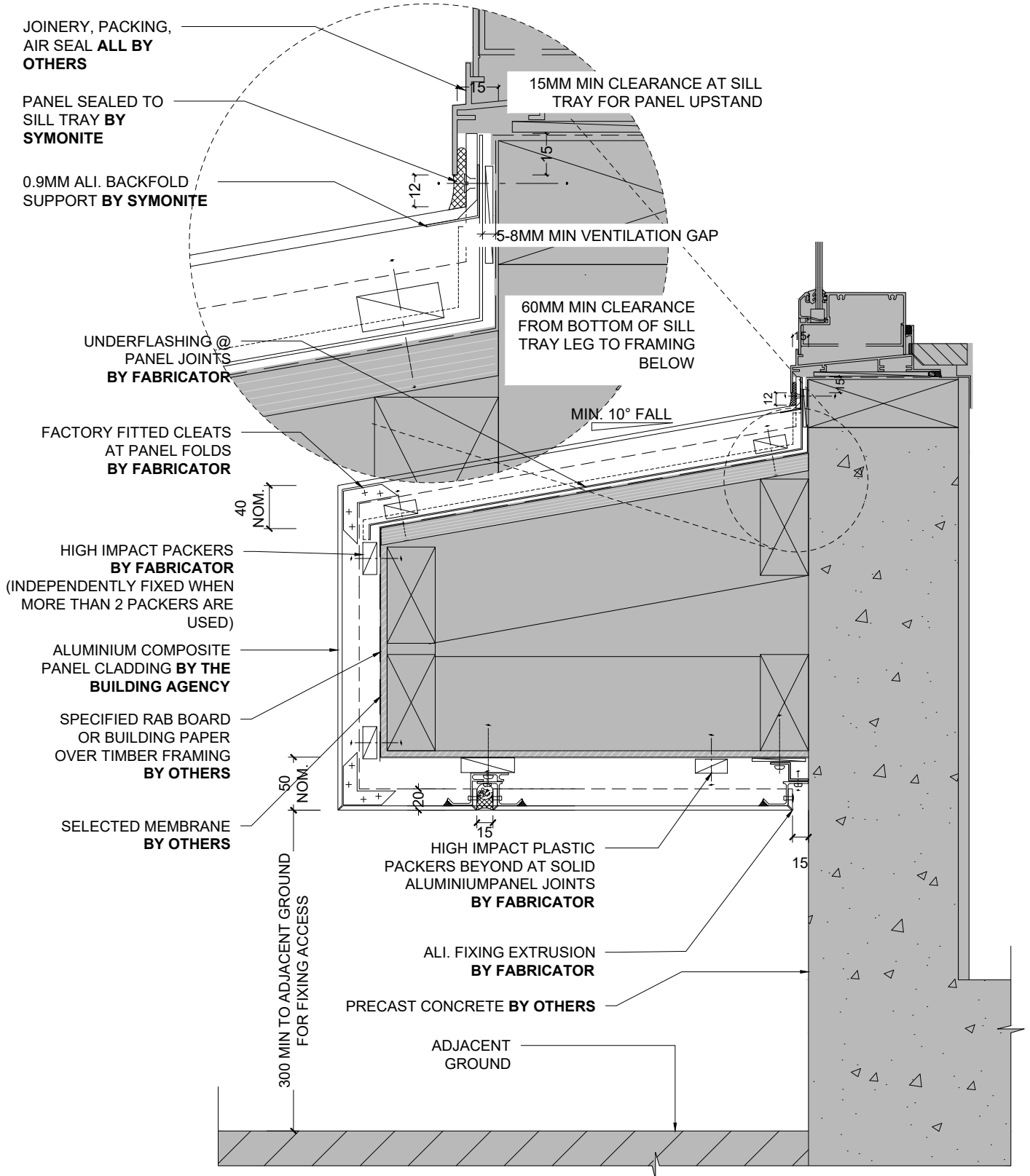

1 TYPICAL EYEBROW SILL DETAIL (SECTION)
1:5 @ A4

ALUMINIUM COMPOSITE PANEL CLADDING SYSTEM

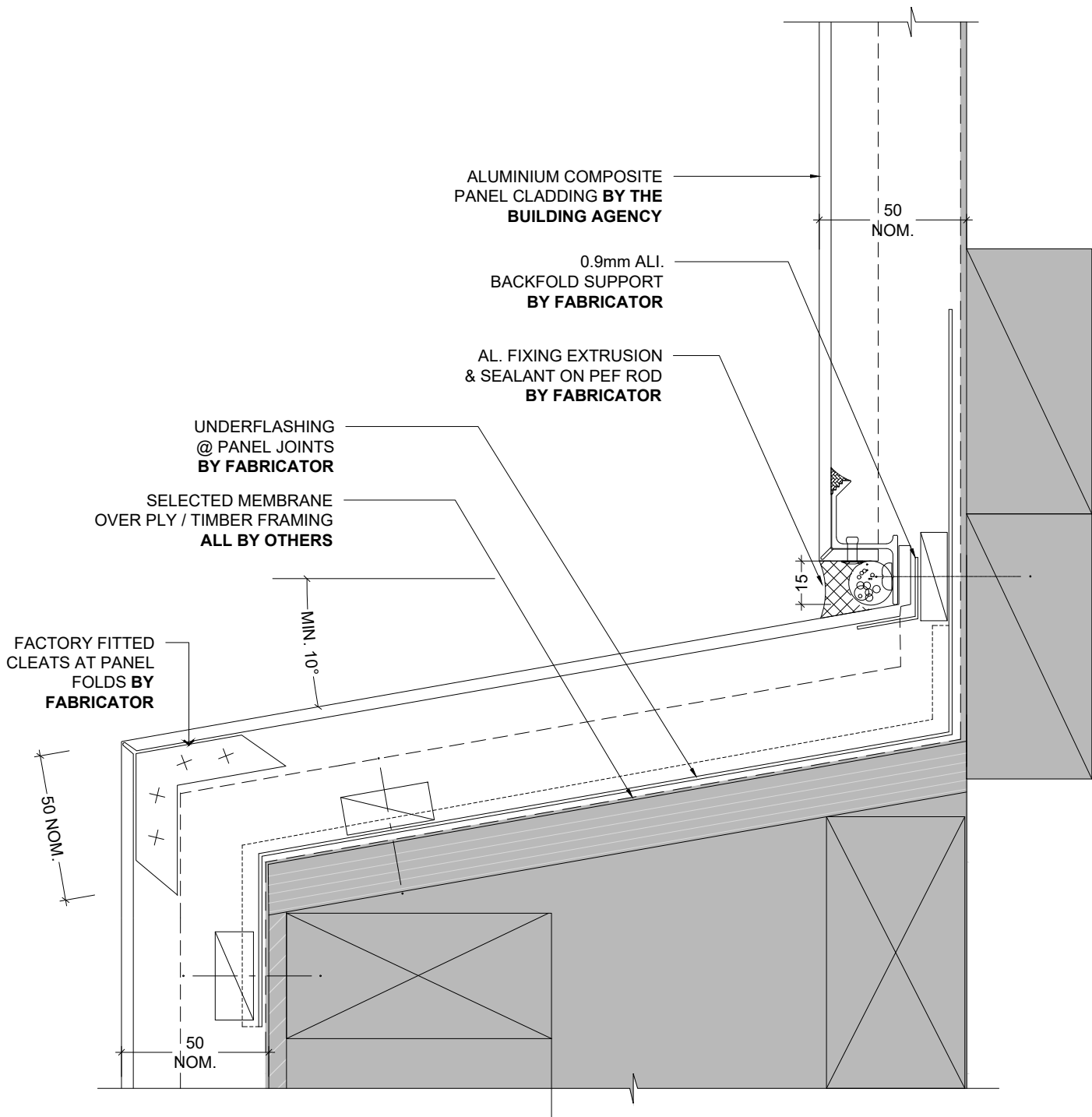

1 TYPICAL UPSTAND DETAIL (SECTION)
- 1:2 @ A4

ALUMINIUM COMPOSITE PANEL CLADDING SYSTEM

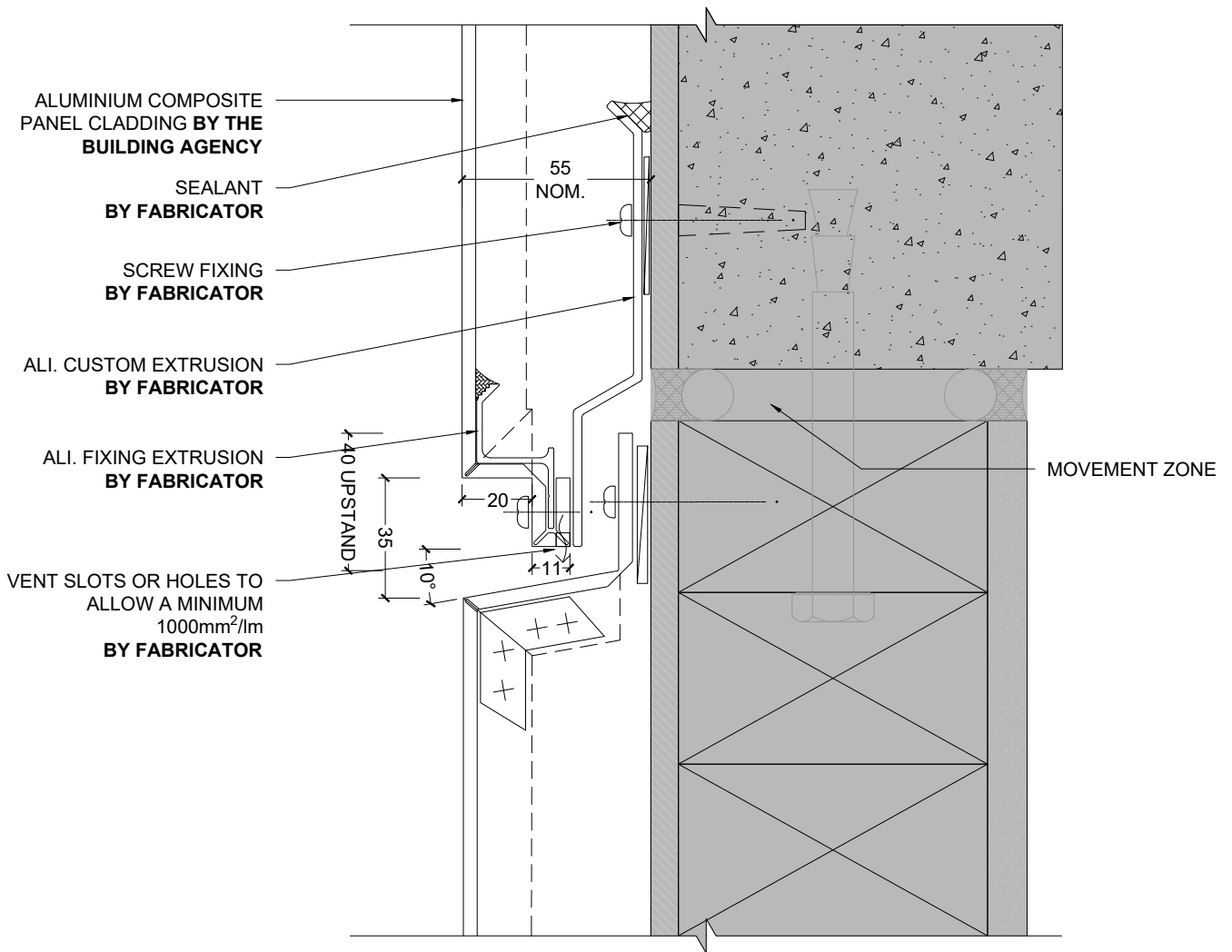

1 INTER-STOREY JOINT (SECTION)
- 1:2 @ A4

ALUMINIUM COMPOSITE PANEL CLADDING SYSTEM

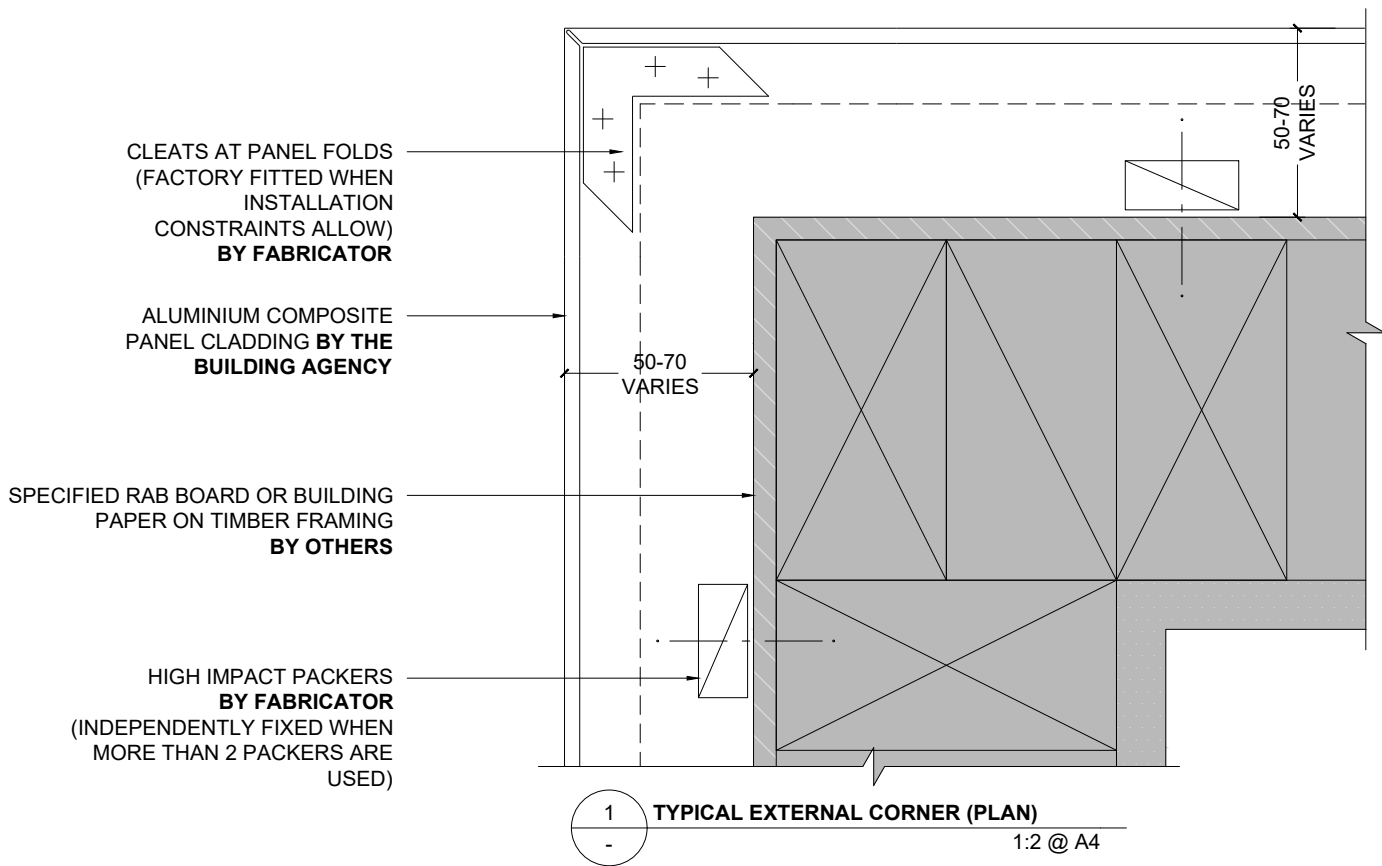

ALUMINIUM COMPOSITE PANEL CLADDING SYSTEM

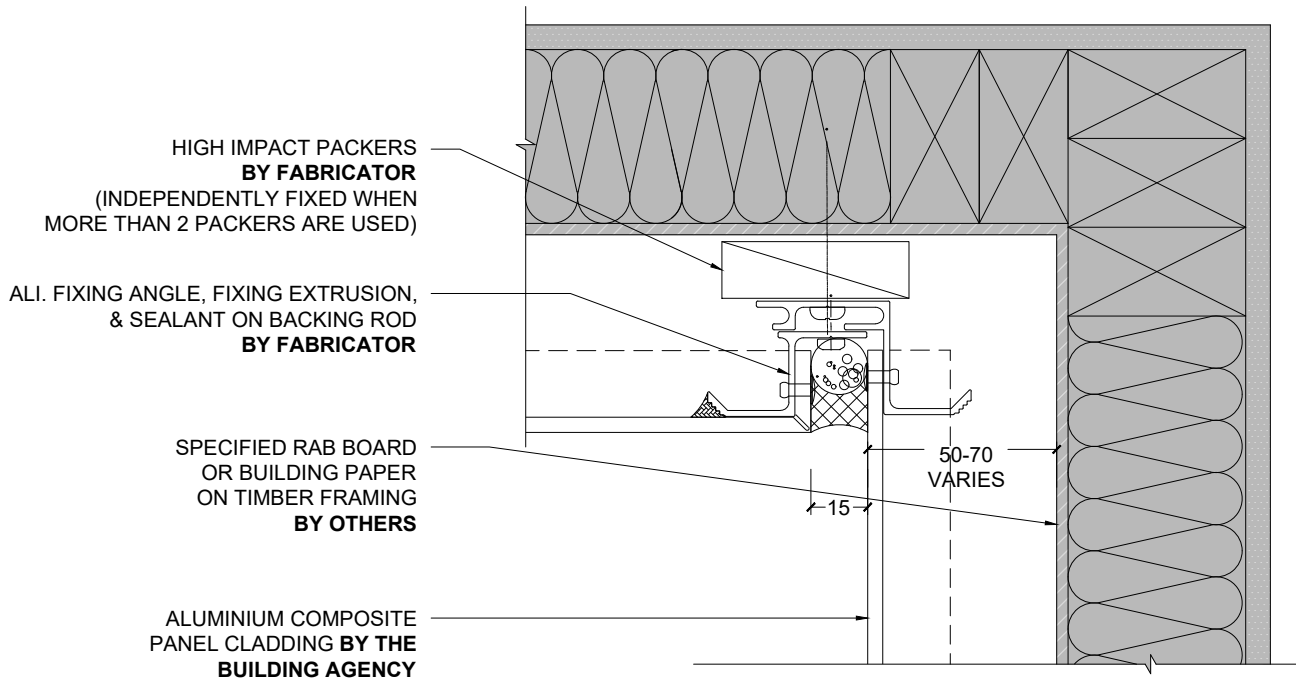

1 TYPICAL VERTICAL INTERNAL CORNER (PLAN)
- 1:2 @ A4

ALUMINIUM COMPOSITE PANEL CLADDING SYSTEM

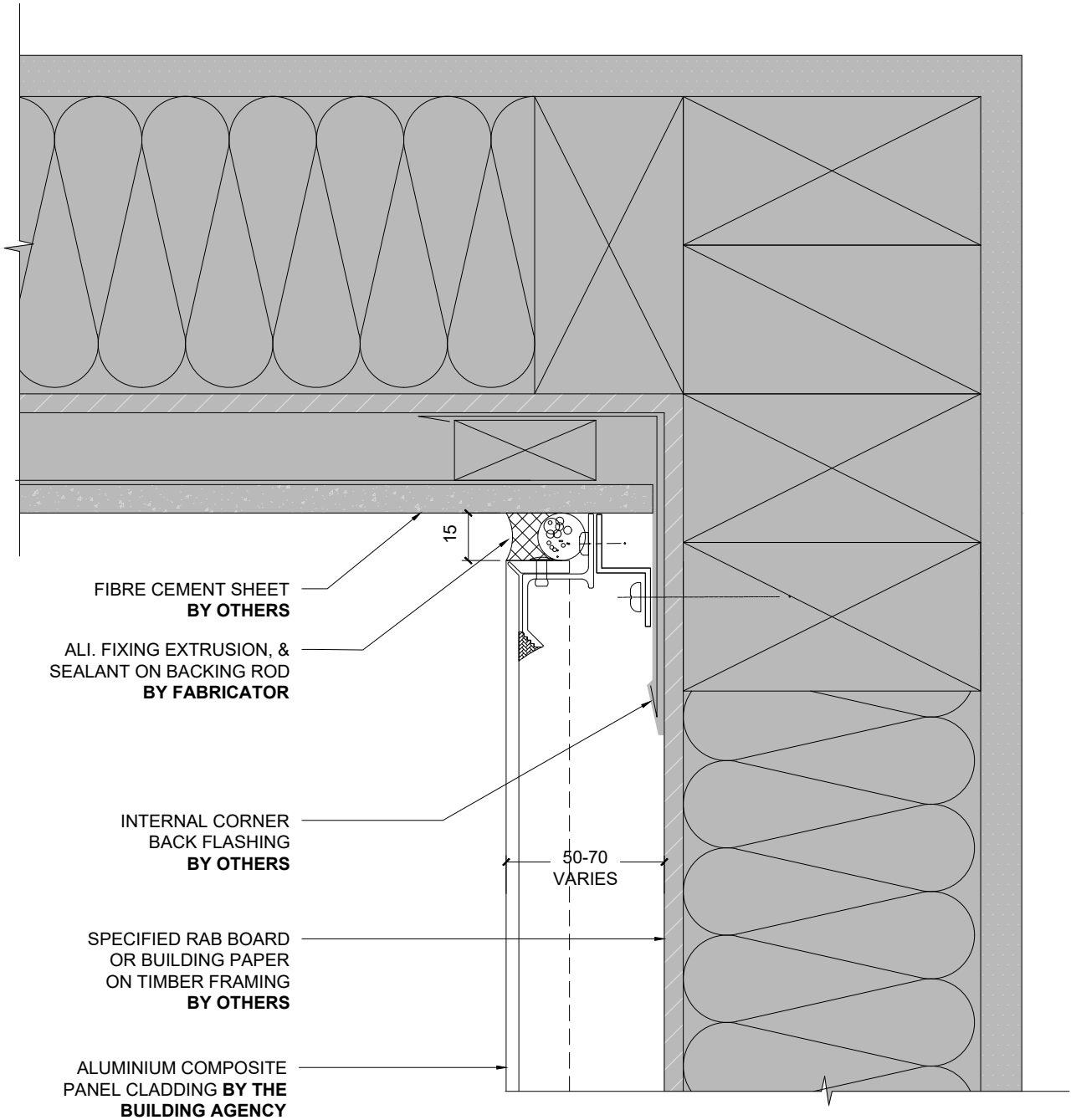

1 FIBRE CEMENT VERTICAL INTERNAL CORNER (PLAN)
-
1:2 @ A4

ALUMINIUM COMPOSITE PANEL CLADDING SYSTEM

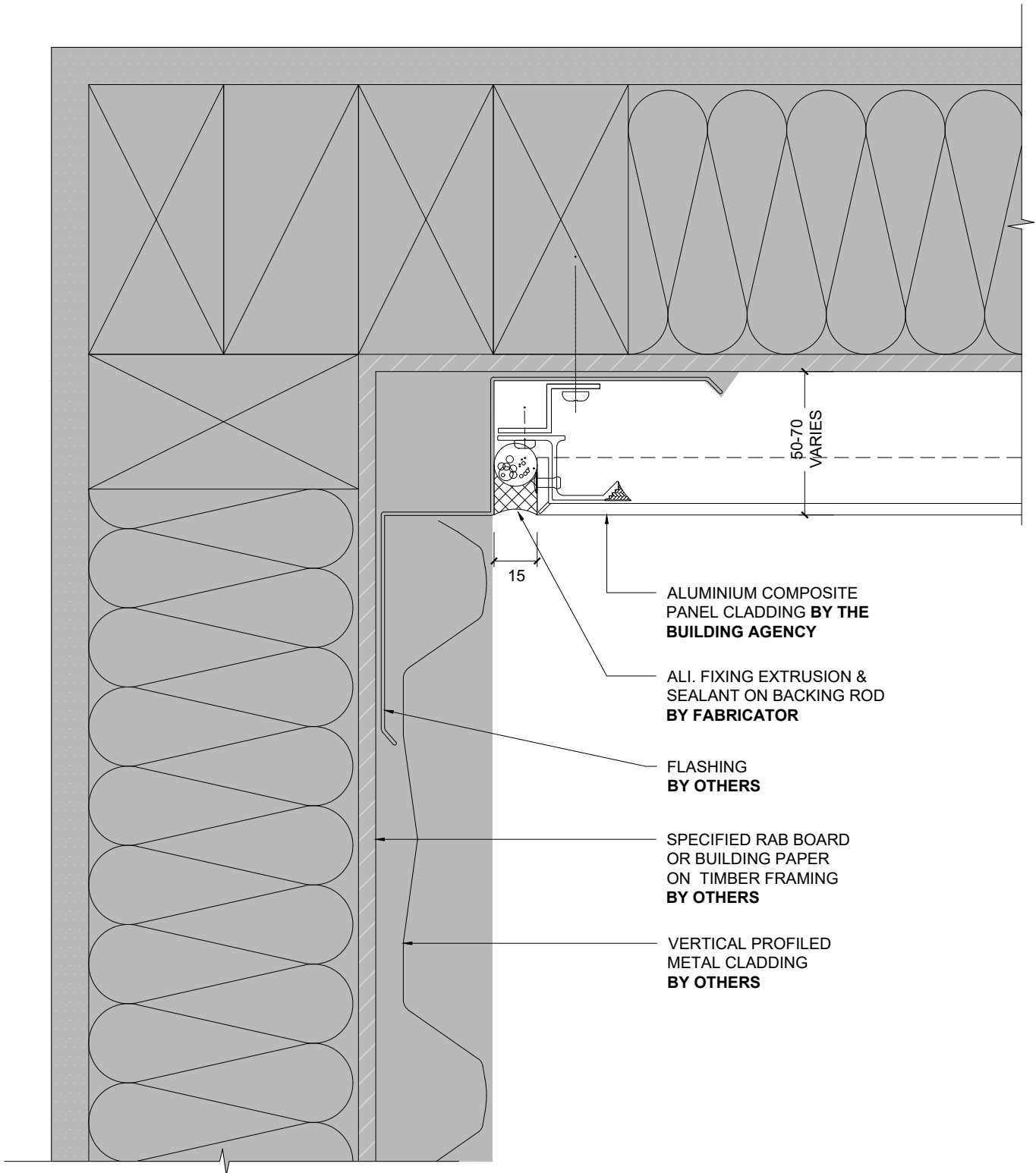

1 VERTICAL PROFILED METAL INTERNAL CORNER (PLAN)
- 1:2 @ A4

ALUMINIUM COMPOSITE PANEL CLADDING SYSTEM

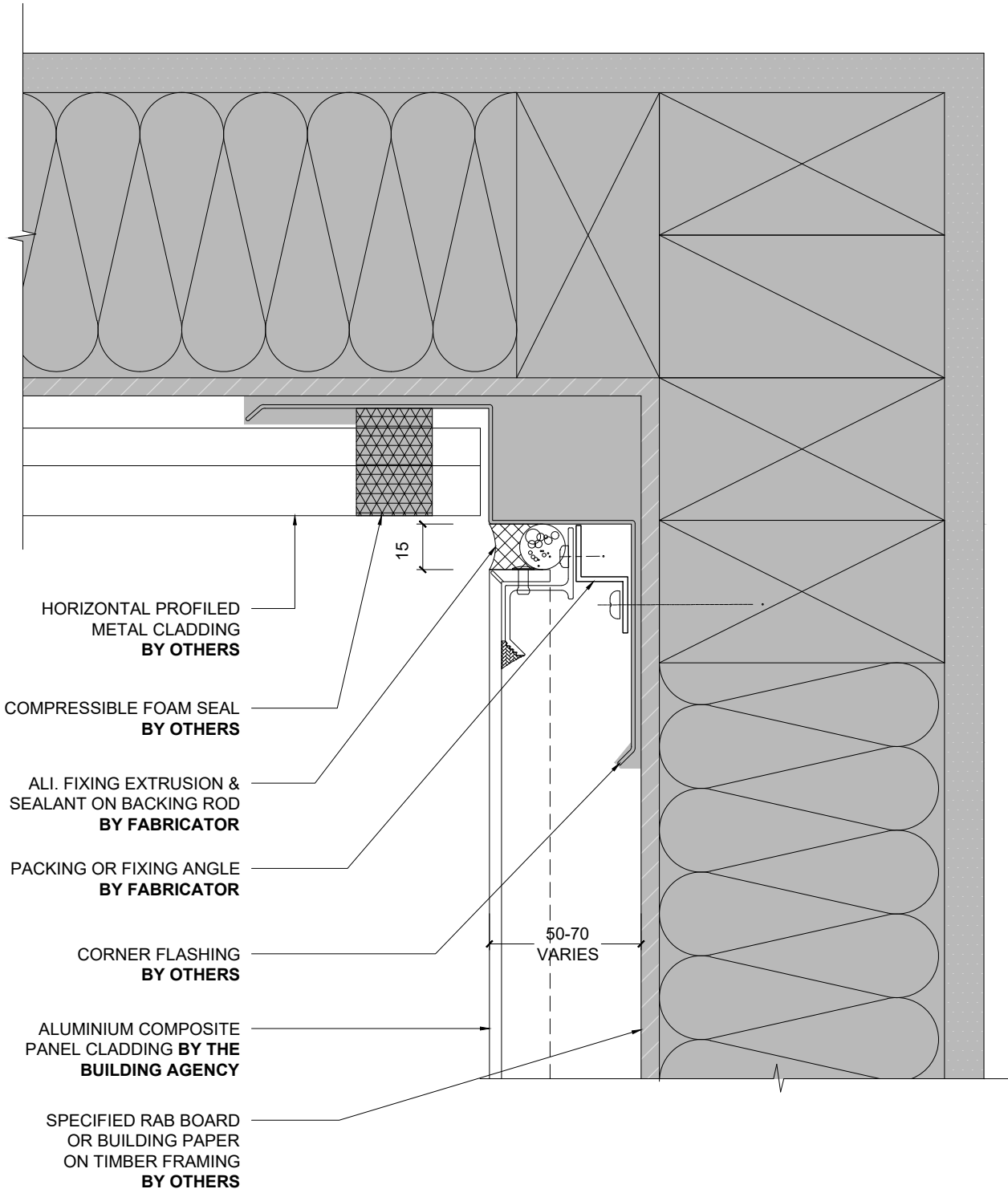

1 HORIZONTAL PROFILED METAL INTERNAL CORNER (PLAN)

1:2 @ A4

ALUMINIUM COMPOSITE PANEL CLADDING SYSTEM

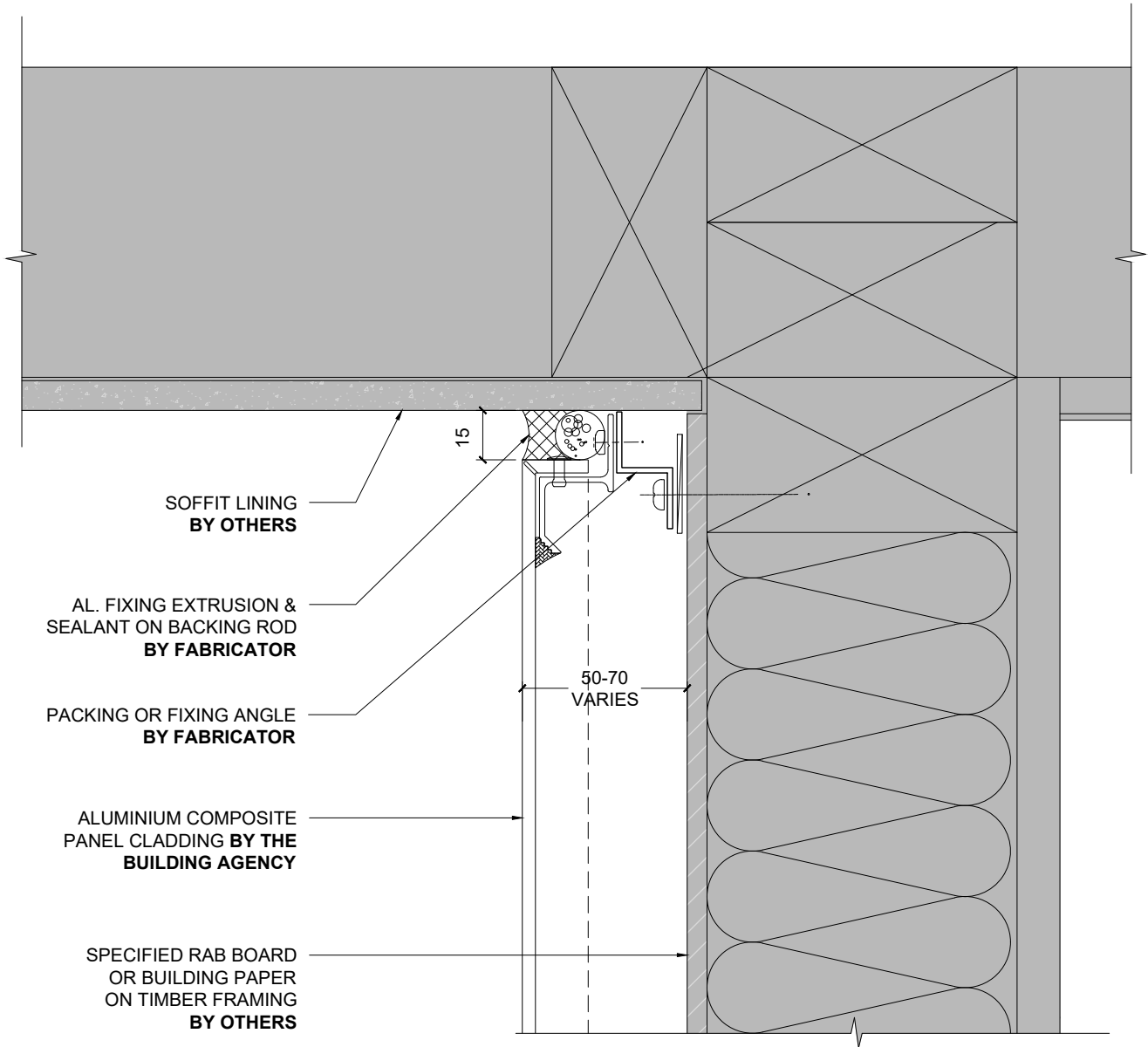

1 TYPICAL WALL TO SOFFIT JUNCTION 1 (SECTION)
- 1:2 @ A4

ALUMINIUM COMPOSITE PANEL CLADDING SYSTEM

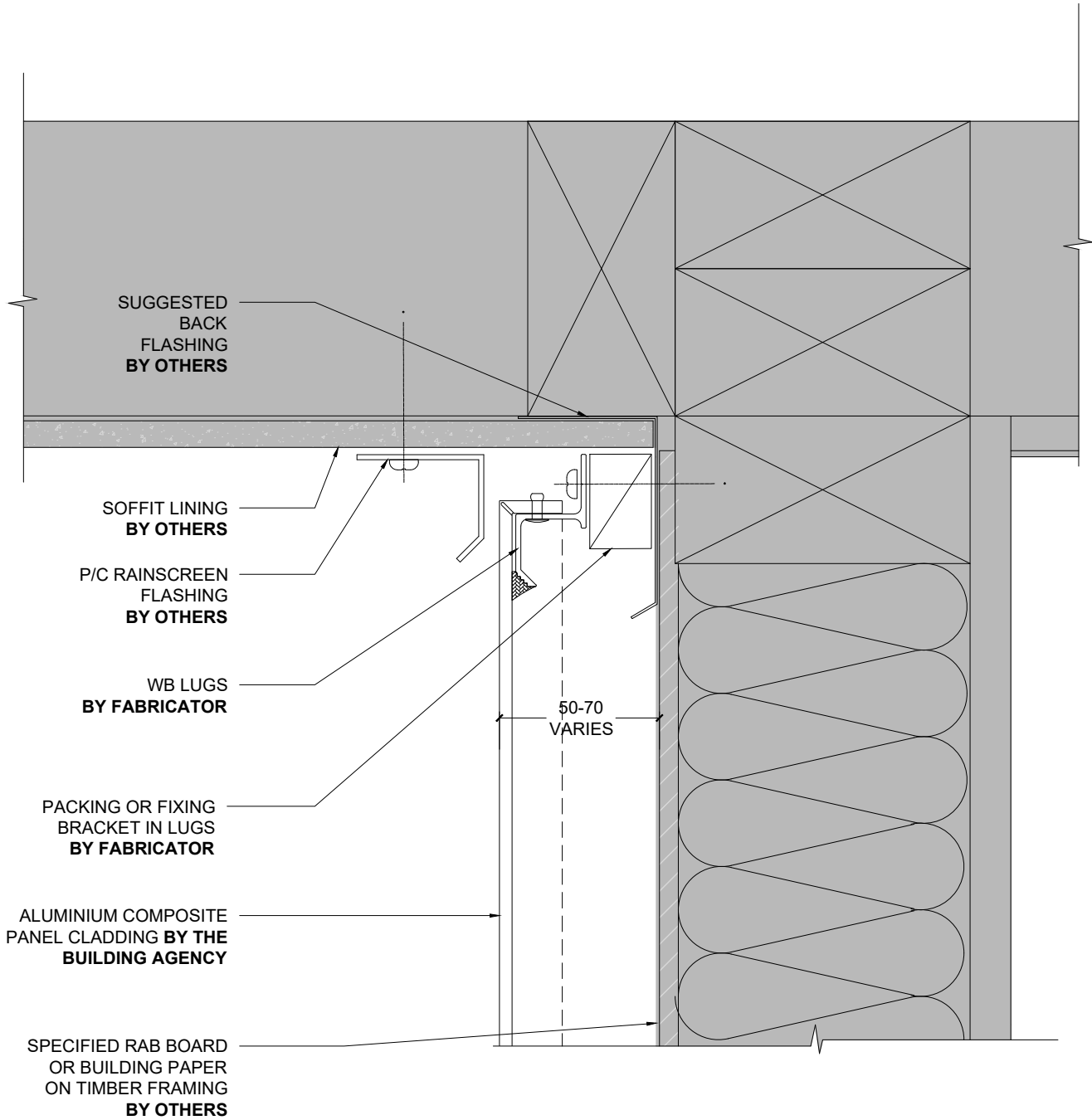

1 TYPICAL WALL TO SOFFIT JUNCTION 2 (SECTION)
- 1:2 @ A4

ALUMINIUM COMPOSITE PANEL CLADDING SYSTEM

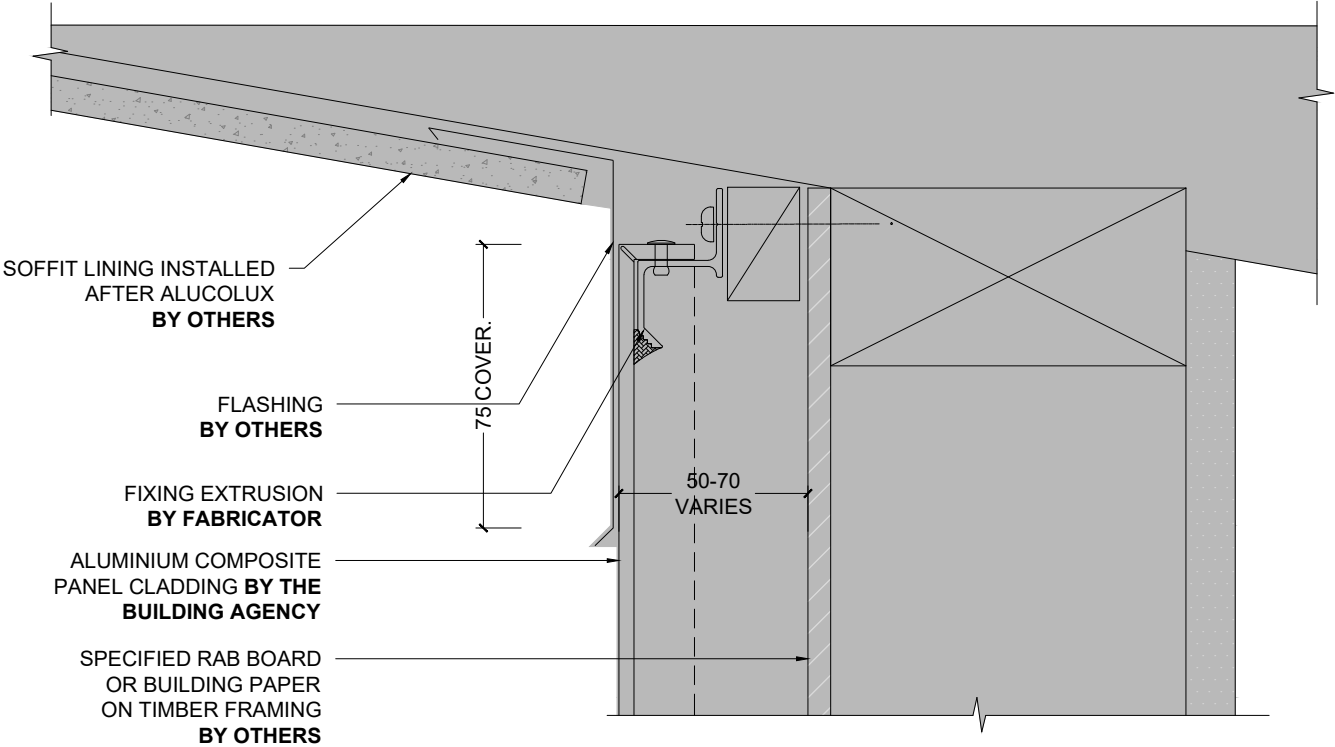

1 WALL TO RAKING SOFFIT JUNCTION 1 (SECTION)
- FULL WEATHER EXPOSURE 1:2 @ A4

ALUMINIUM COMPOSITE PANEL CLADDING SYSTEM

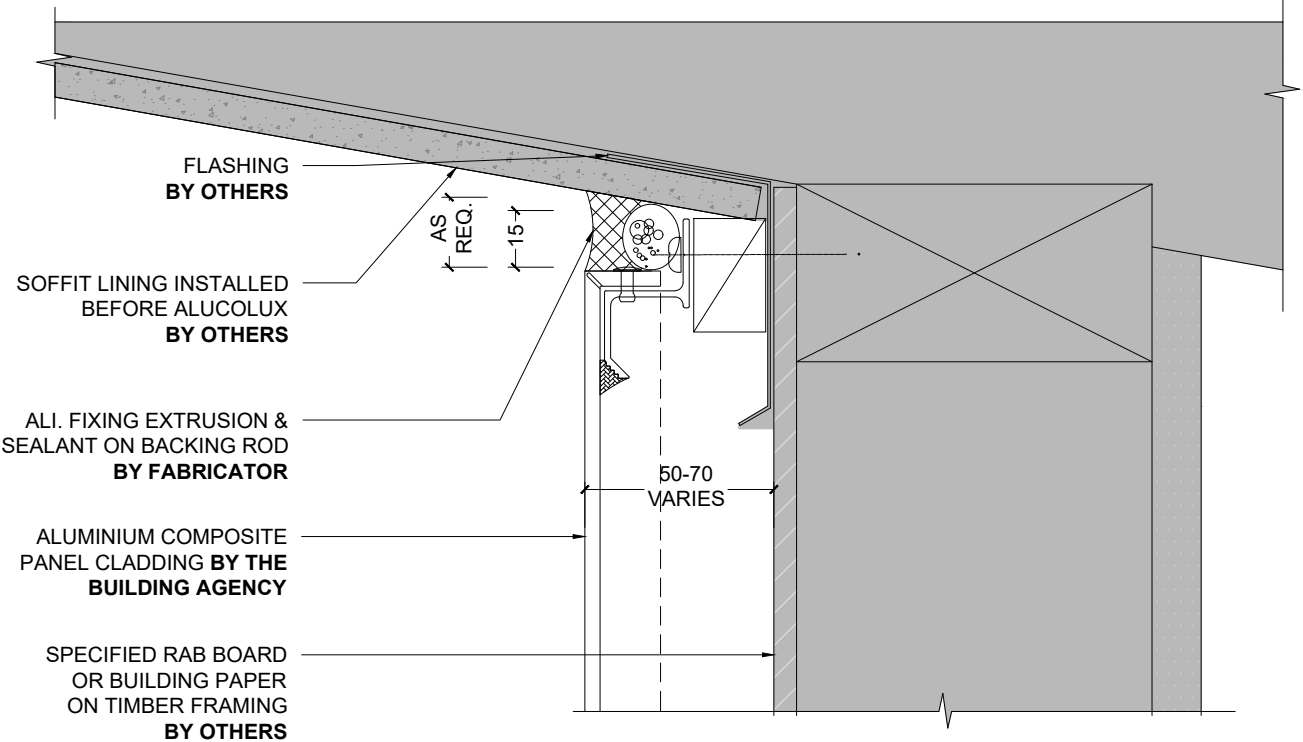

1 WALL TO RAKING SOFFIT JUNCTION 2 (SECTION)
- INTERIOR OR LOW WEATHER EXPOSURE 1:2 @ A4

ALUMINIUM COMPOSITE PANEL CLADDING SYSTEM

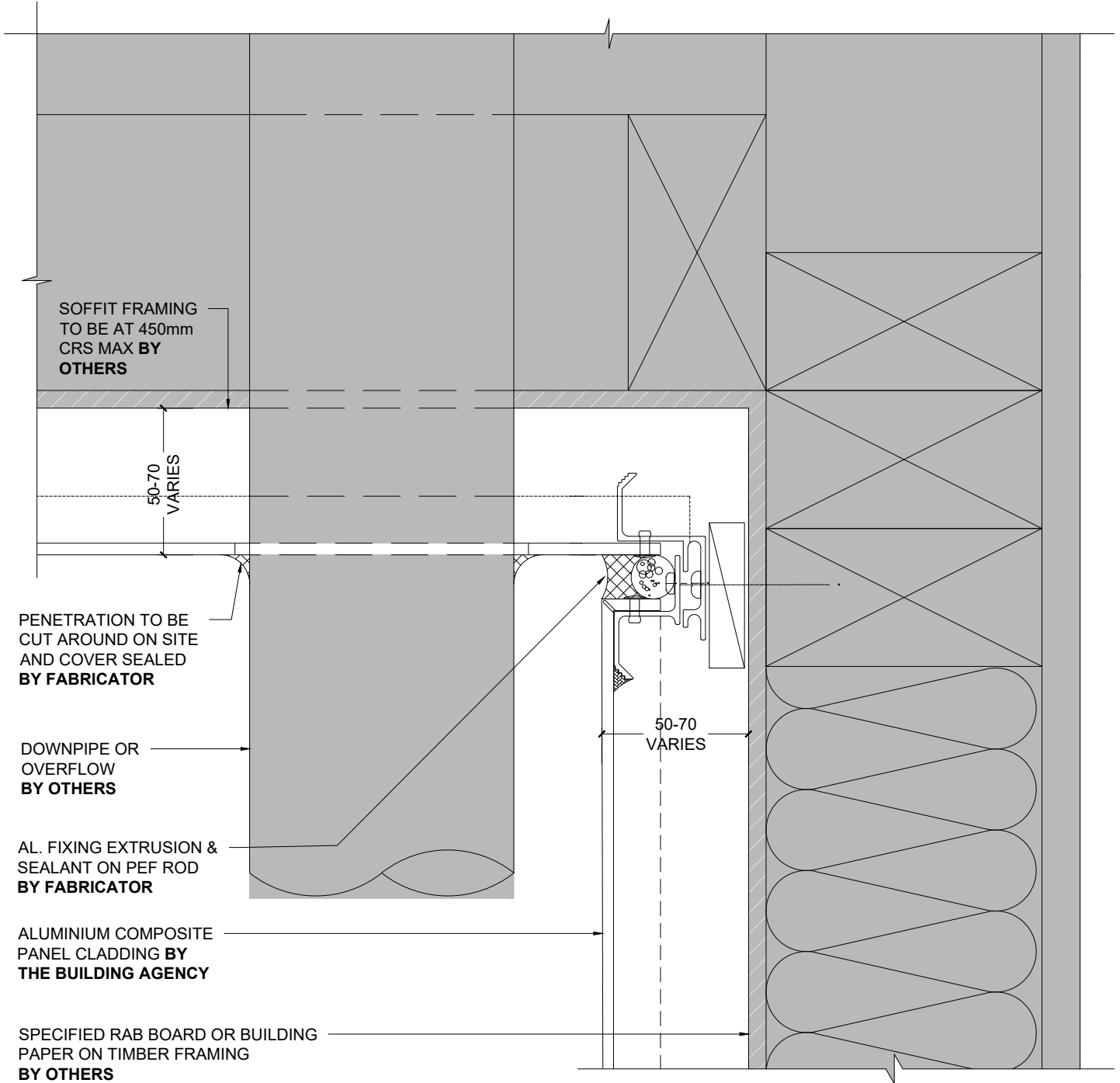

WALL TO SOFFIT JUNCTION & DOWNPIPE PENETRATION (SECTION)

1:2 @ A4

ALUMINIUM COMPOSITE PANEL CLADDING SYSTEM

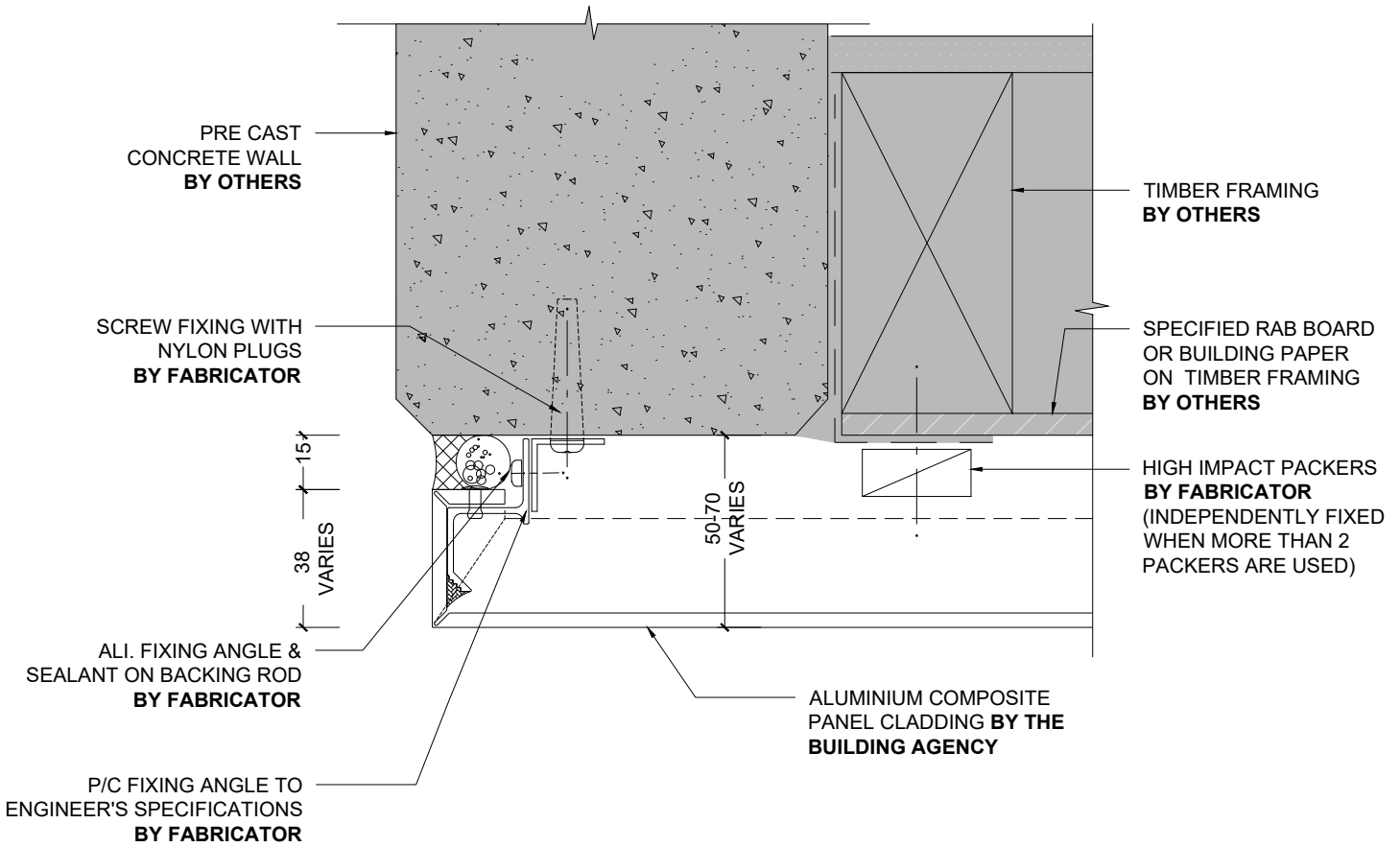

1 PRECAST CONCRETE WALL JUNCTION 1 (PLAN)

1:2 @ A4

ALUMINIUM COMPOSITE PANEL CLADDING SYSTEM

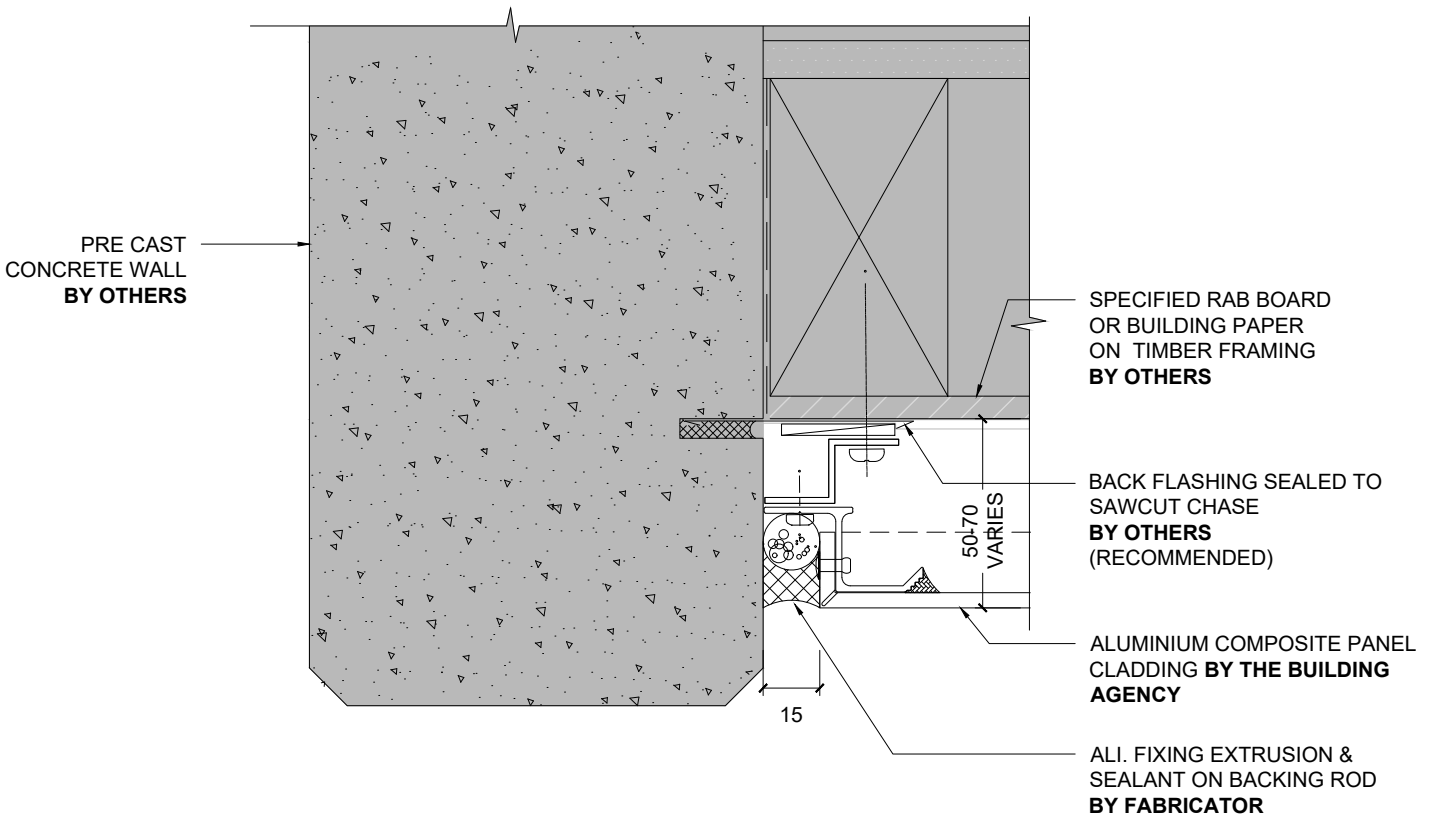

1 PRECAST CONCRETE WALL JUNCTION 2 (PLAN)
-
1:2 @ A4

NOTE: CHASED FLASHING IS RECOMMENDED AT ALL VERTICAL CONCRETE JUNCTION DETAILS. IT IS THE BUILDING DESIGNER'S RESPONSIBILITY TO CHECK WITH APPLICABLE LOCAL BUILDING AUTHORITIES AS TO WHETHER THIS IS REQUIRED

ALUMINIUM COMPOSITE PANEL CLADDING SYSTEM

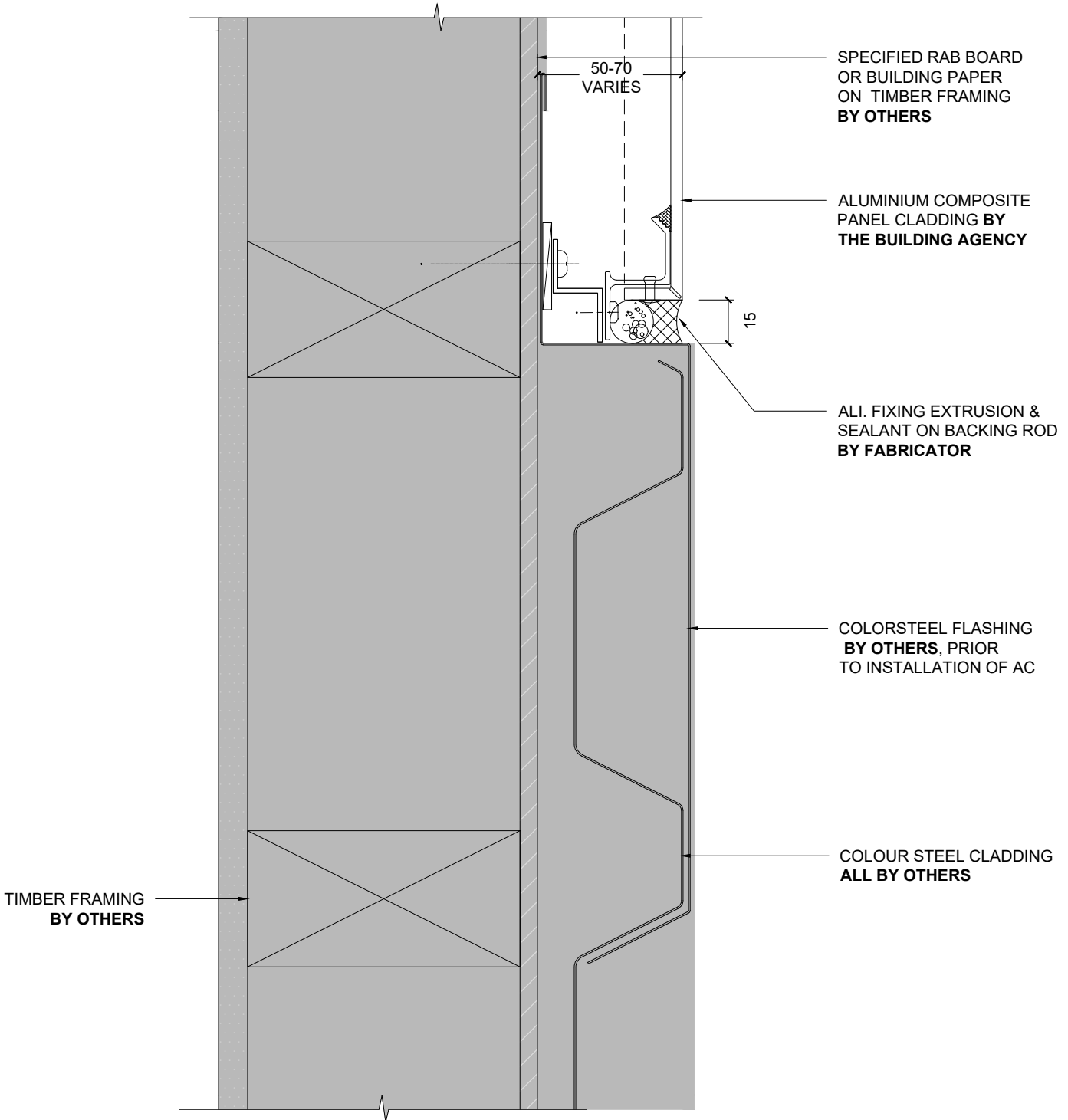

1 VERTICAL PROFILED METAL JUNCTION (PLAN)
-
1:2 @ A4