

frontek
cerámica tecnológica en fachadas



92 MM STUD WALL INSTALLATION VERTICAL CONFIGURATION

FRONTEK AUSTRALIA PTY LTD.

www.frontek.com.au

+61 2 9316 6818

Vertical Configuration **STUD WALL**

STANDARD MODULE

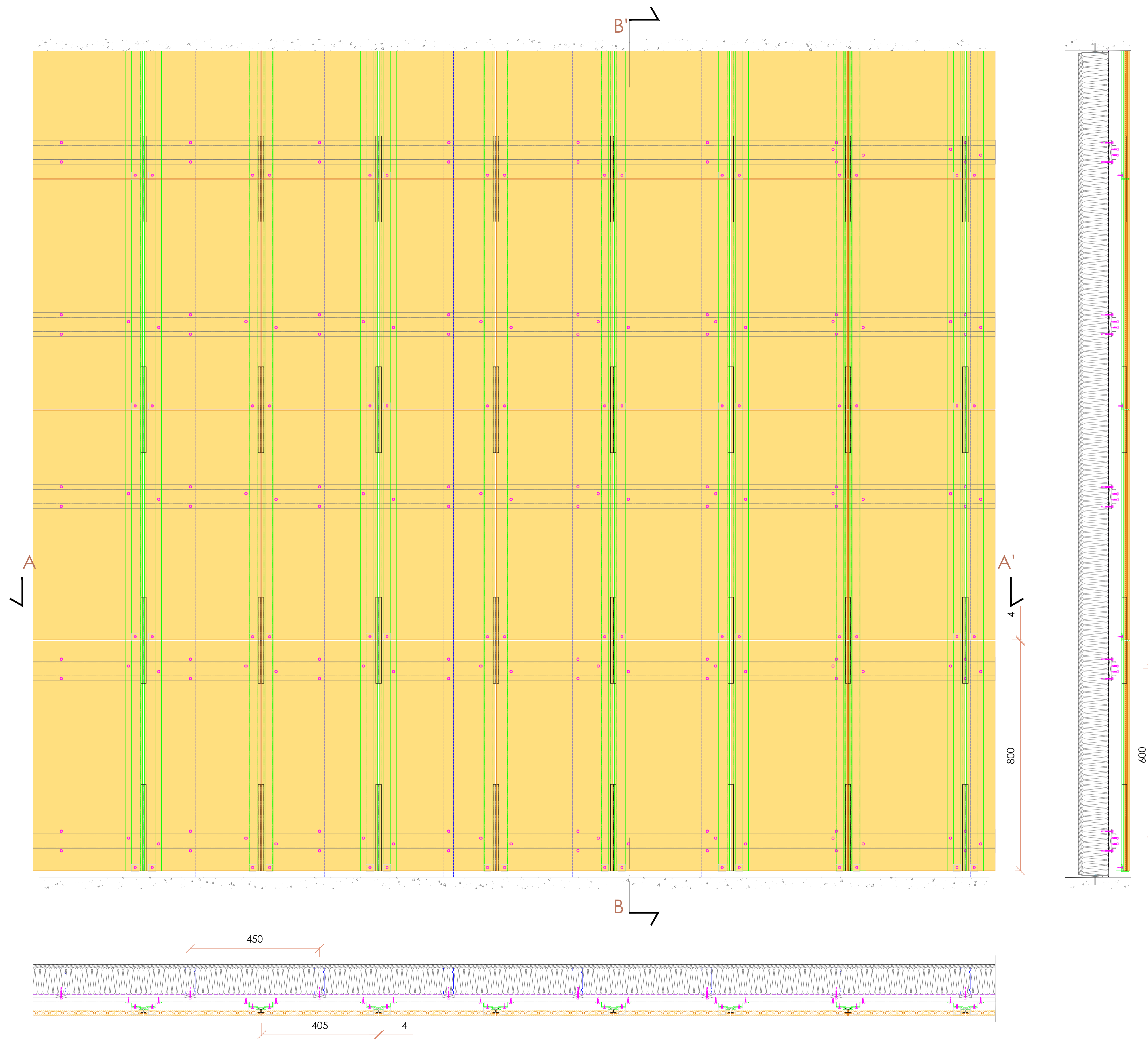

FOR INFORMATION

COPYRIGHT

These designs, details and/or specifications and the Copyright Therein, remain the property of

Frontek Australia.

and shall not be divulged in any form whatsoever without written permission of

Frontek Australia.

All fixings sizes and types to be engineered by constructors

DRAWING DESCRIPTION
STANDARD MODULE

FACADE TYPE
92 MM STUD WALL

FRONTEK SYSTEM
VERTICAL CONFIGURATION

DRAWN BY
BEATRIZ QUINTANA

FIRST DRAWN DATE 16/05/2018

REVIEWED BY
-

SCALE 1/150 SIZE A3

DRAWING NO. V100

frontek
cerámica tecnológica en fachadas

FRONTEK AUSTRALIA PTY LTD.
www.frontek.com.au
+61 2 9316 6818

Vertical Configuration STUD WALL

ASSEMBLING PROCESS

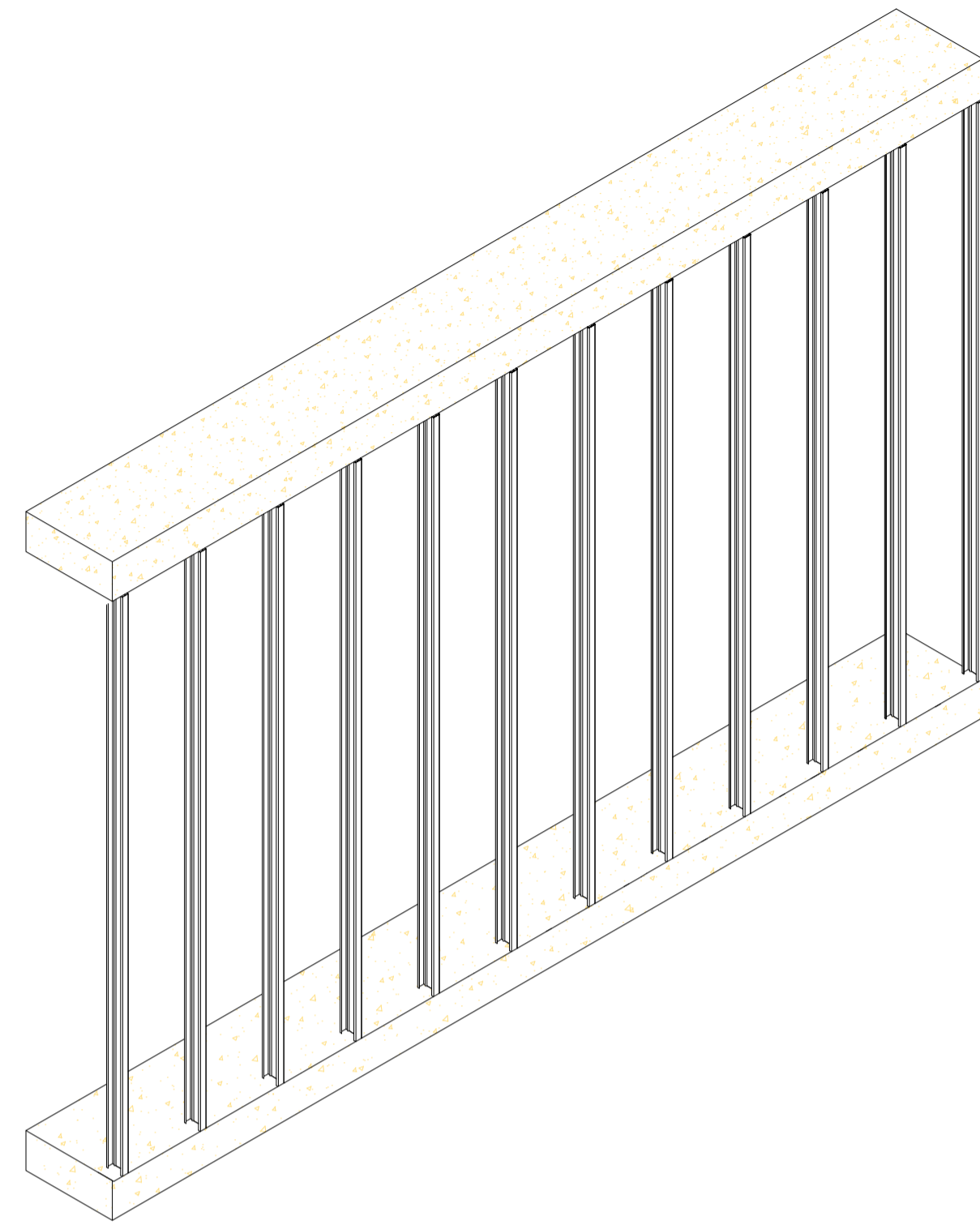

1. STUD WALL

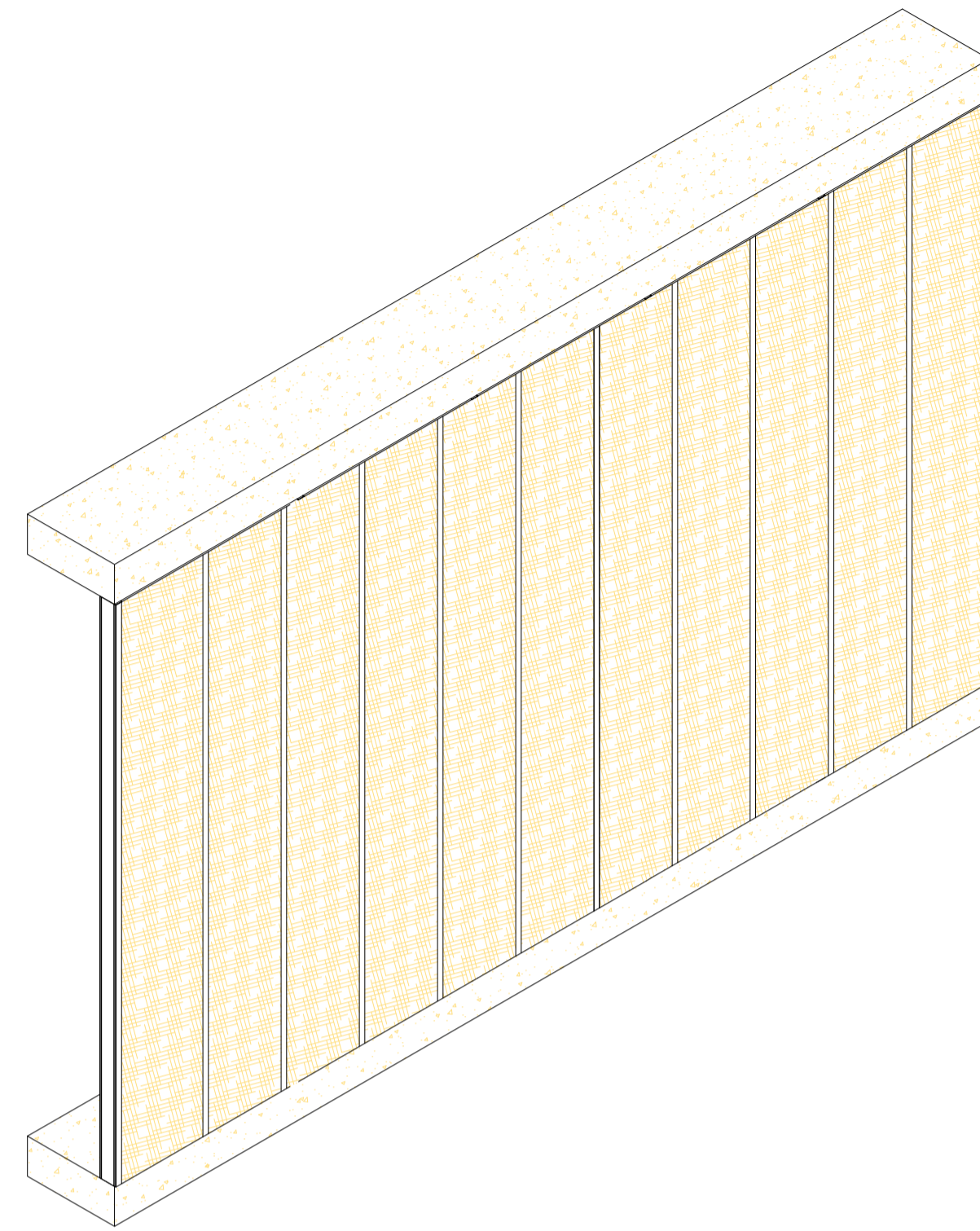

2. ENGINEERED BACKPAN

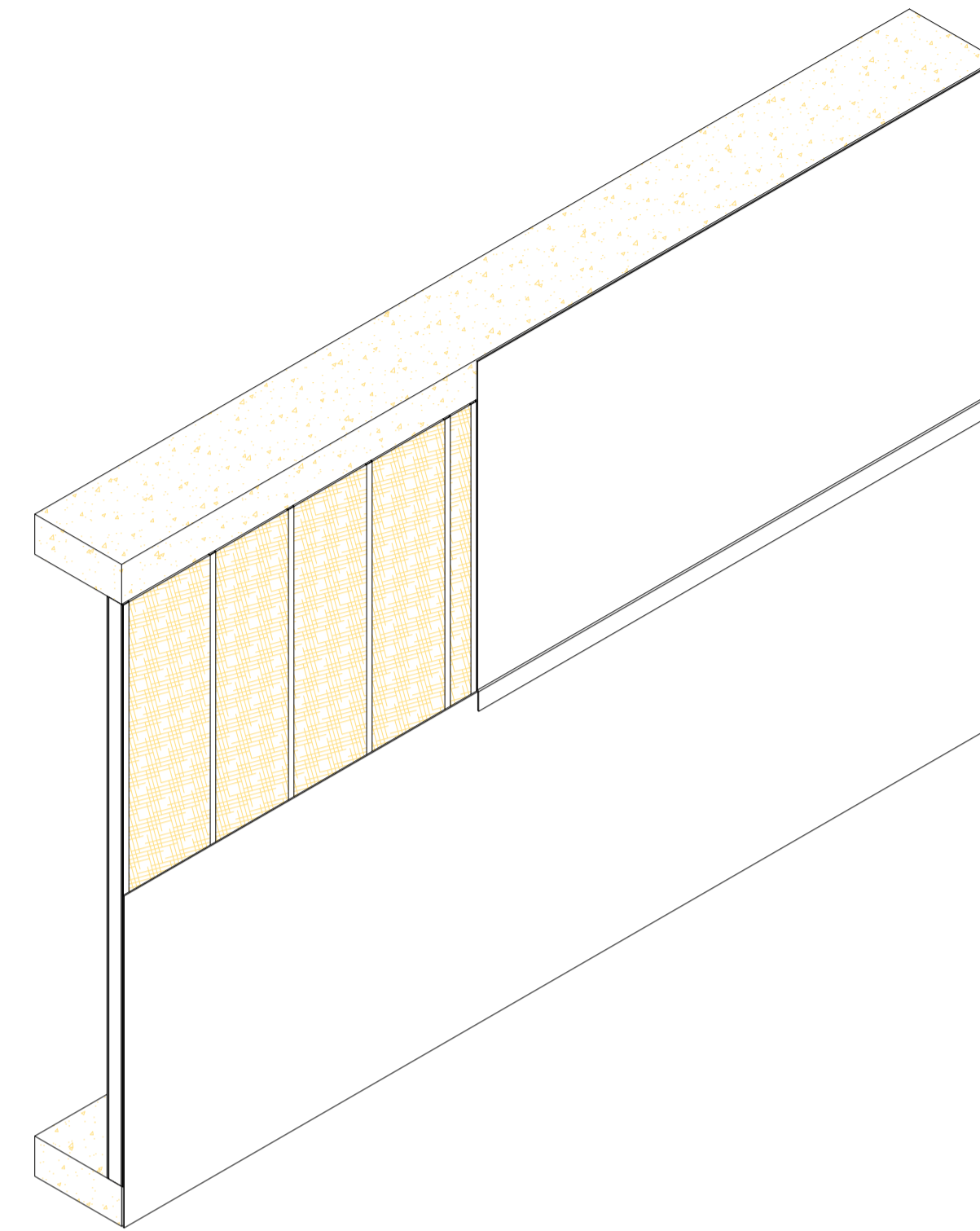

3. ENGINEERED BACKPAN

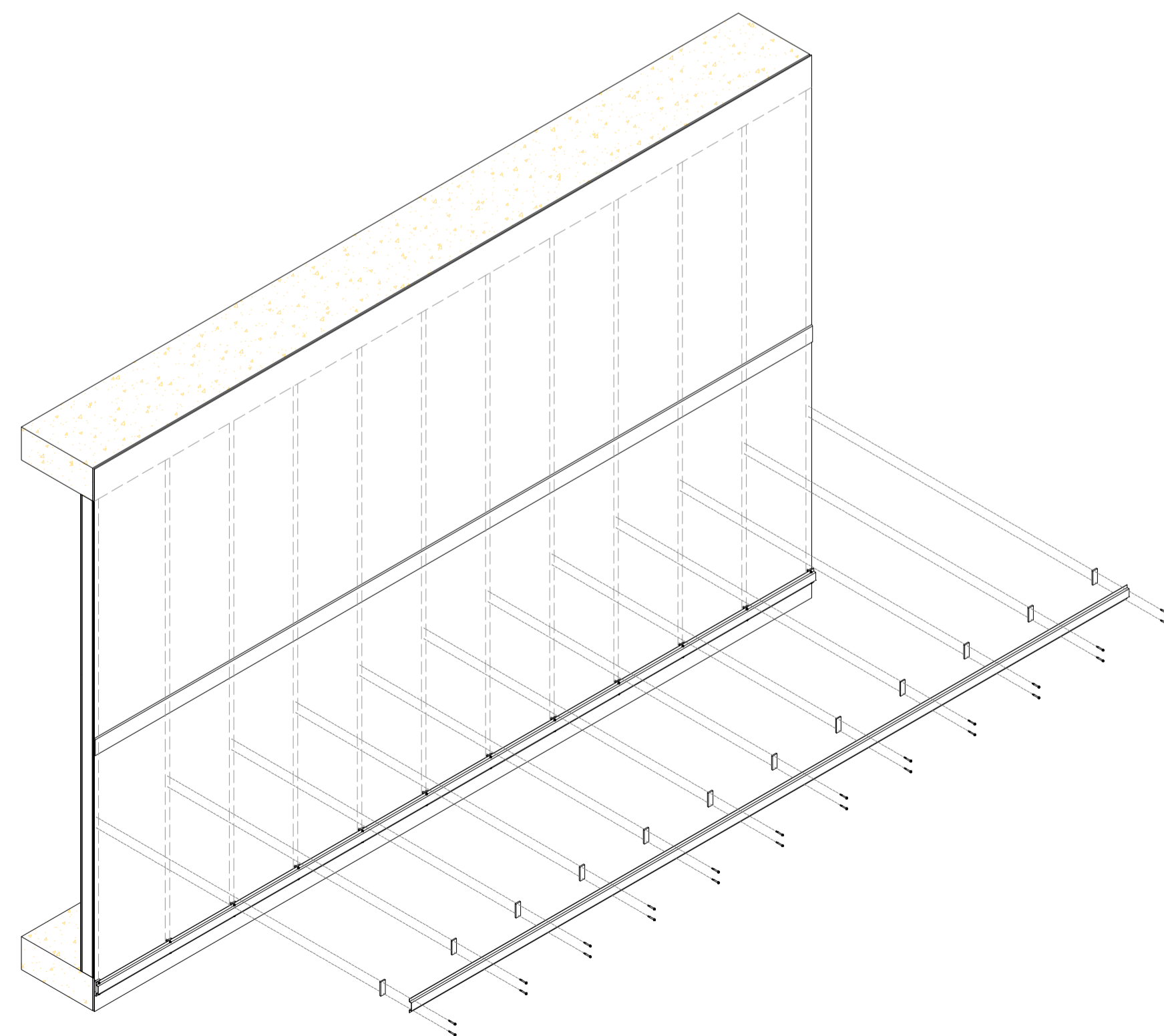

4. TOP HAT 15 MM GALVANIZED STEEL

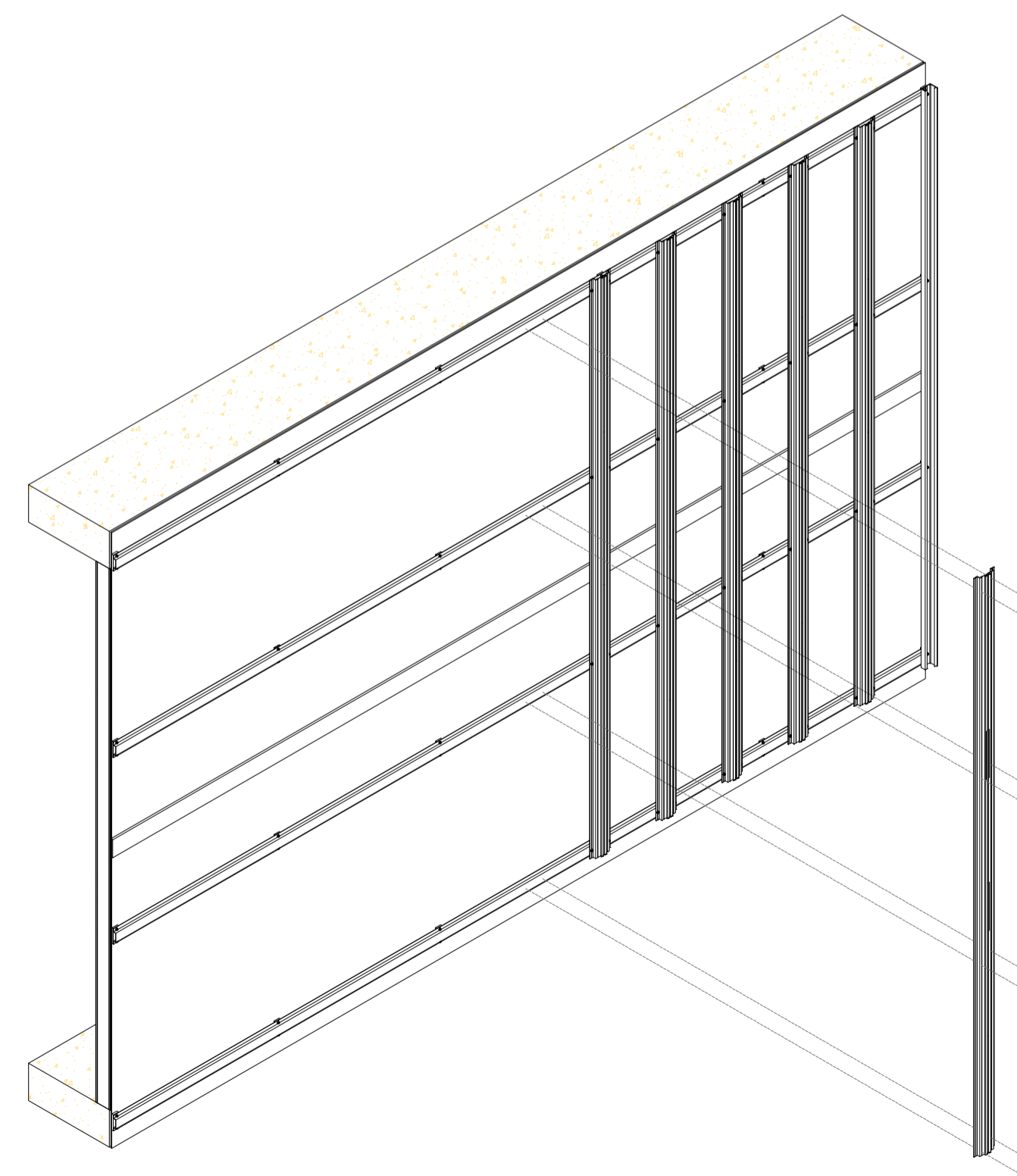

5. FRONTEK FT03-01 [1] VERTICAL WALL HUNG/CEILING INSTALLATION RAIL

FOR INFORMATION

COPYRIGHT

These designs, details and/or specifications and the Copyright Therein, remain the property of

Frontek Australia.

and shall not be divulged in any form whatsoever without written permission of

Frontek Australia.

All fixings sizes and types to be engineered by constructors

DRAWING DESCRIPTION
ASSEMBLING PROCESS

FACADE TYPE
92 MM STUD WALL

FRONTEK SYSTEM
VERTICAL CONFIGURATION

DRAWN BY
BEATRIZ QUINTANA

FIRST DRAWN DATE 16/05/2018

REVIEWED BY
-

SCALE 1/20 SIZE A3

DRAWING NO. V101

frontek
cerámica tecnológica en fachadas

FRONTEK AUSTRALIA PTY LTD.
www.frontek.com.au
+61 2 9316 6818

Vertical Configuration STUD WALL

ASSEMBLING PROCESS

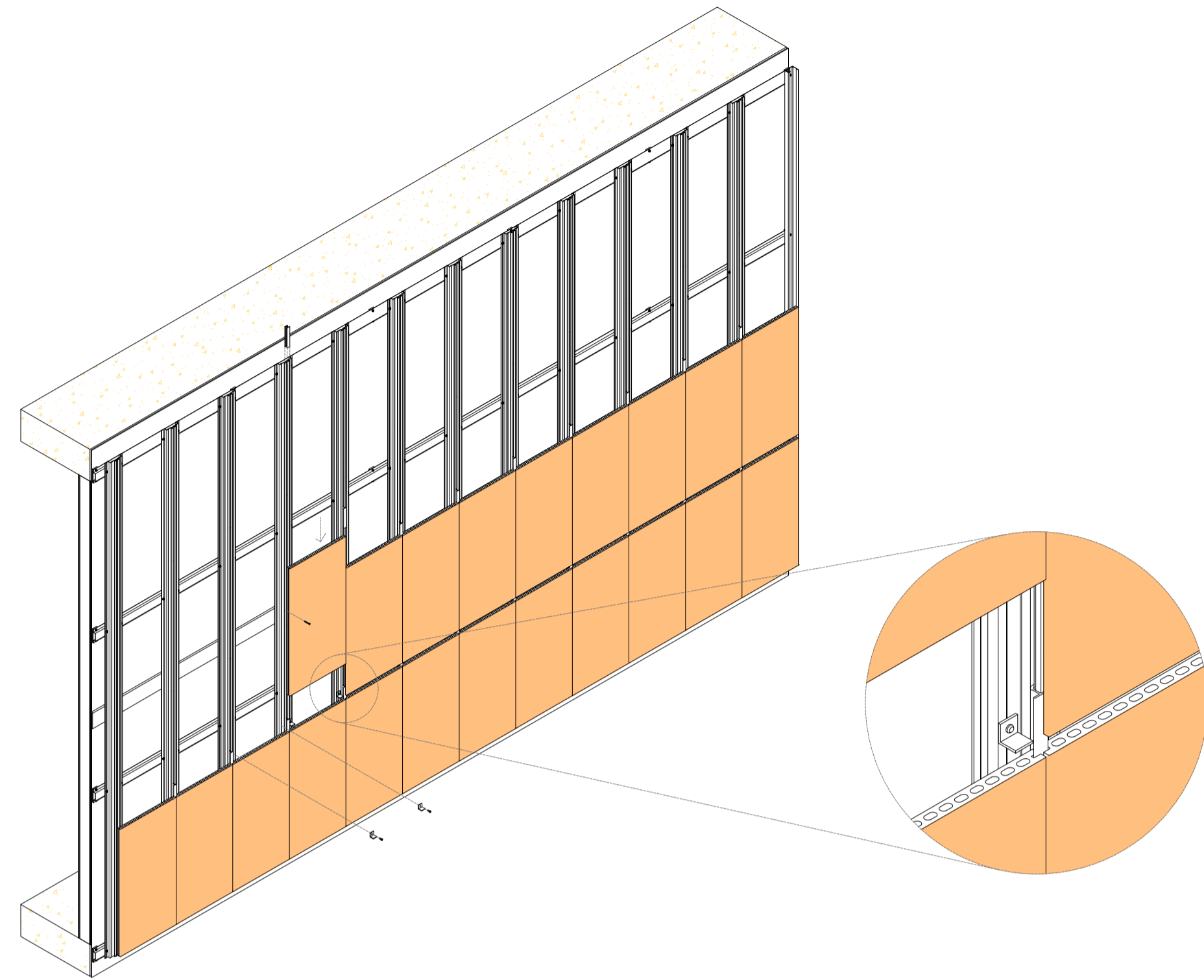

6A. VERTICAL NET PATTERN CONFIGURATION:
FT01-01 [1] VERTICAL WALL HUNG/CEILING INSTALL. RAIL CLIP
WITH SCREW

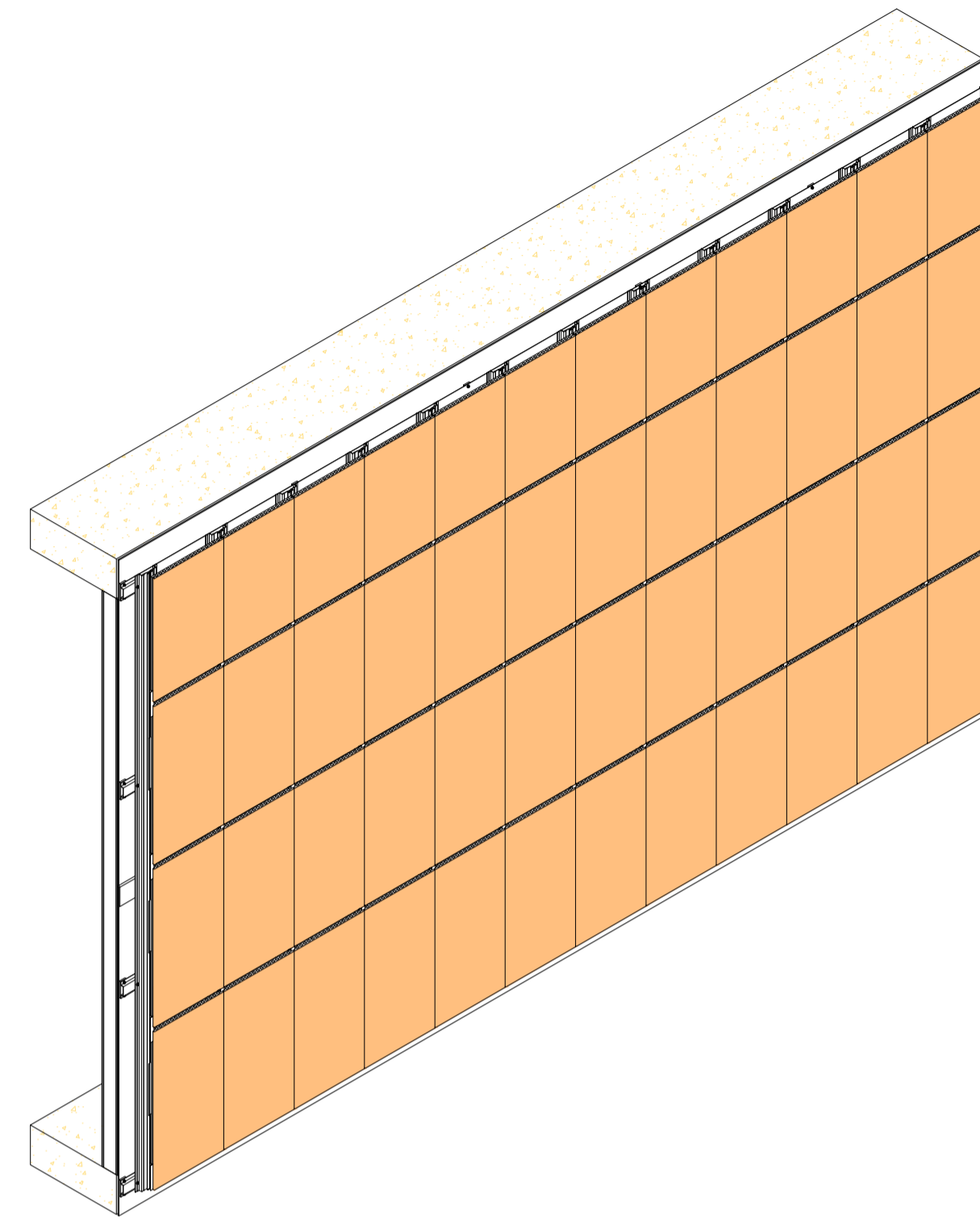

7A. VERTICAL NET PATTERN CONFIGURATION

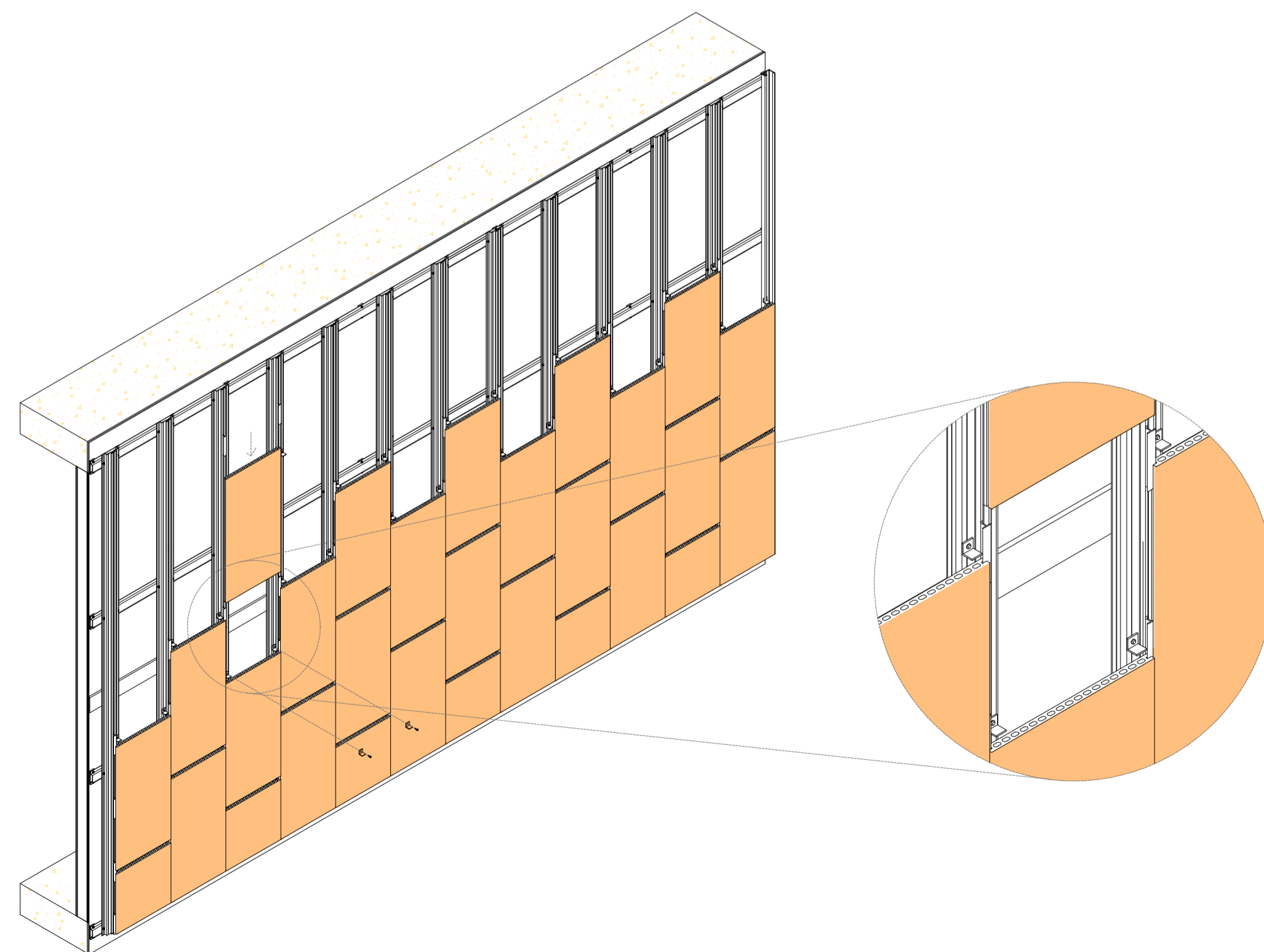

6B. VERTICAL BRICK PATTERN CONFIGURATION:
FT01-01 [1] VERTICAL WALL HUNG/CEILING INSTALL.
RAIL CLIP WITH SCREW

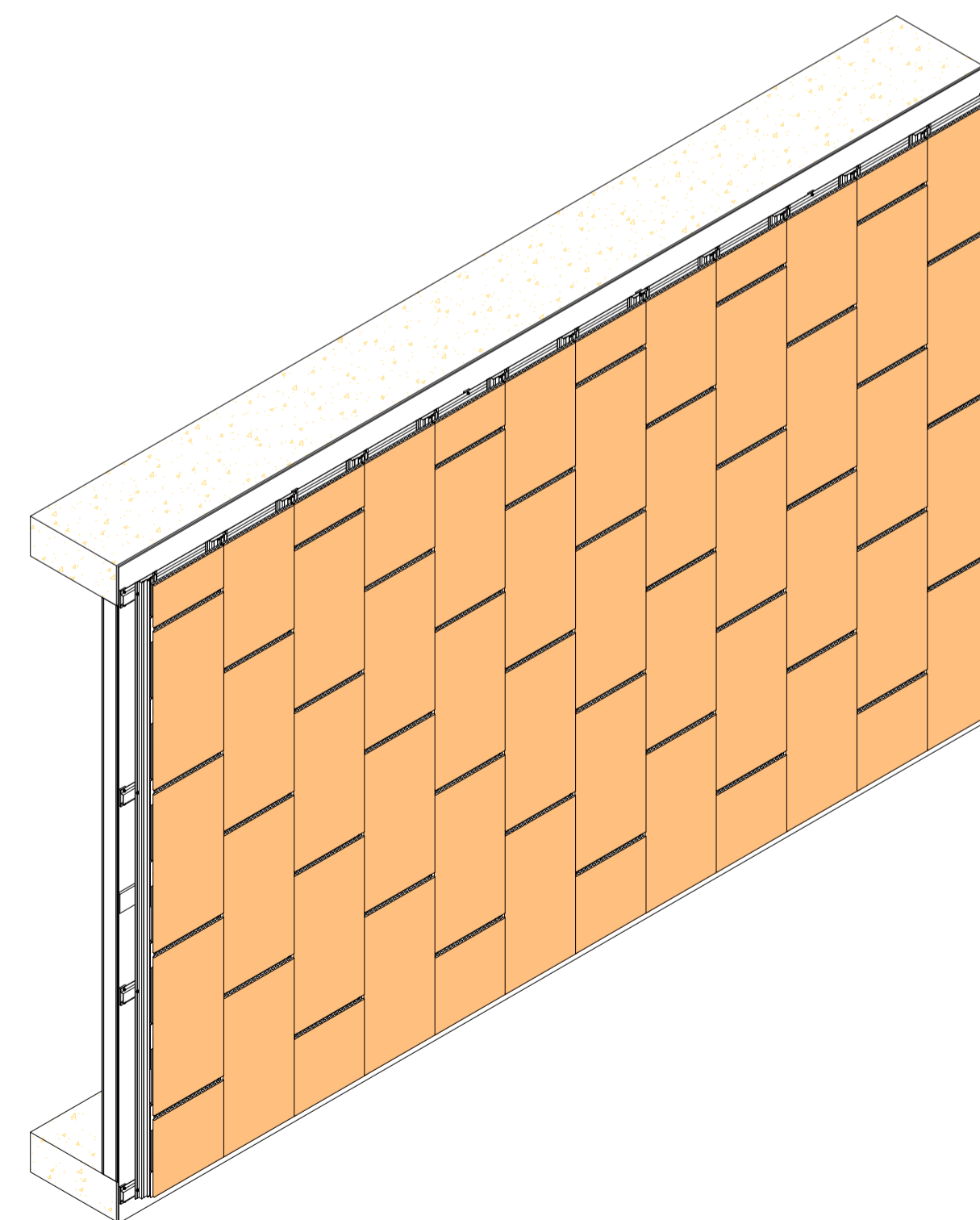

7B. VERTICAL BRICK PATTERN CONFIGURATION

FOR INFORMATION

COPYRIGHT

These designs, details and/or specifications and the Copyright Therein, remain the property of

Frontek Australia.

and shall not be divulged in any form whatsoever without written permission of

Frontek Australia.

All fixings sizes and types to be engineered by constructors

DRAWING DESCRIPTION
ASSEMBLING PROCESS

FACADE TYPE
92 MM STUD WALL

FRONTEK SYSTEM
VERTICAL CONFIGURATION

DRAWN BY
BEATRIZ QUINTANA

FIRST DRAWN DATE 16/05/2018

REVIEWED BY
-

SCALE 1/20 SIZE A3

DRAWING NO. V102

frontek
cerámica tecnológica en fachadas

FRONTEK AUSTRALIA PTY LTD.
www.frontek.com.au
+61 2 9316 6818

Vertical Configuration STUD WALL

VERTICAL SECTION.

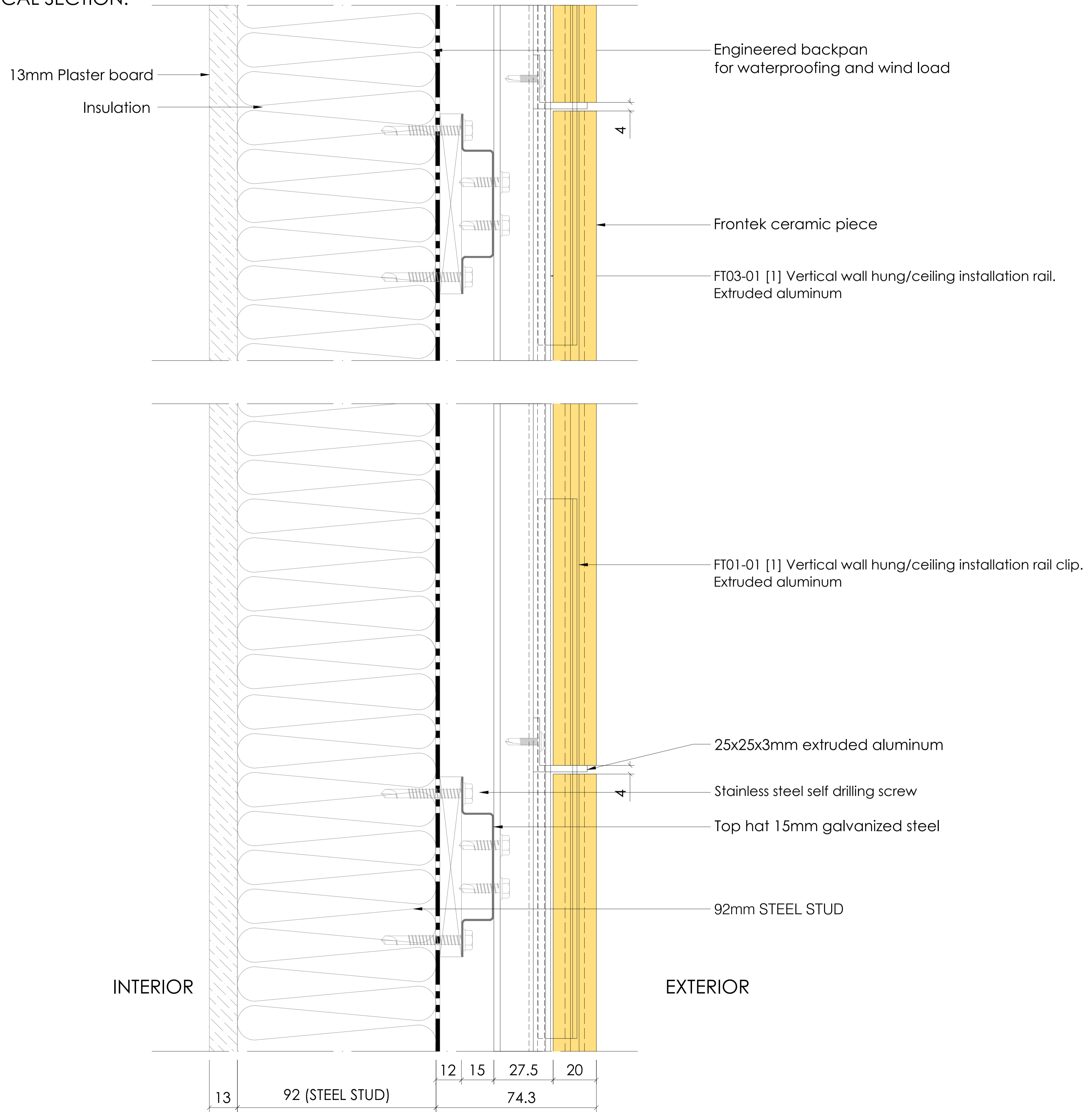

FOR INFORMATION

COPYRIGHT
 These designs, details and/or specifications and the Copyright Therein, remain the property of **Frontek Australia.** and shall not be divulged in any form whatsoever without written permission of **Frontek Australia.**

All fixings sizes and types to be engineered by constructors

DRAWING DESCRIPTION
 VERTICAL SECTION

FACADE TYPE
 92 MM STUD WALL

FRONTEK SYSTEM
 VERTICAL CONFIGURATION

DRAWN BY
 BEATRIZ QUINTANA

FIRST DRAWN DATE 16/05/2018

REVIEWED BY
 -

SCALE 1/20 SIZE A3

DRAWING NO. D101



FRONTEK AUSTRALIA PTY LTD.
 www.frontek.com.au
 +61 2 9316 6818

Vertical Configuration STUD WALL

VERTICAL SECTION.

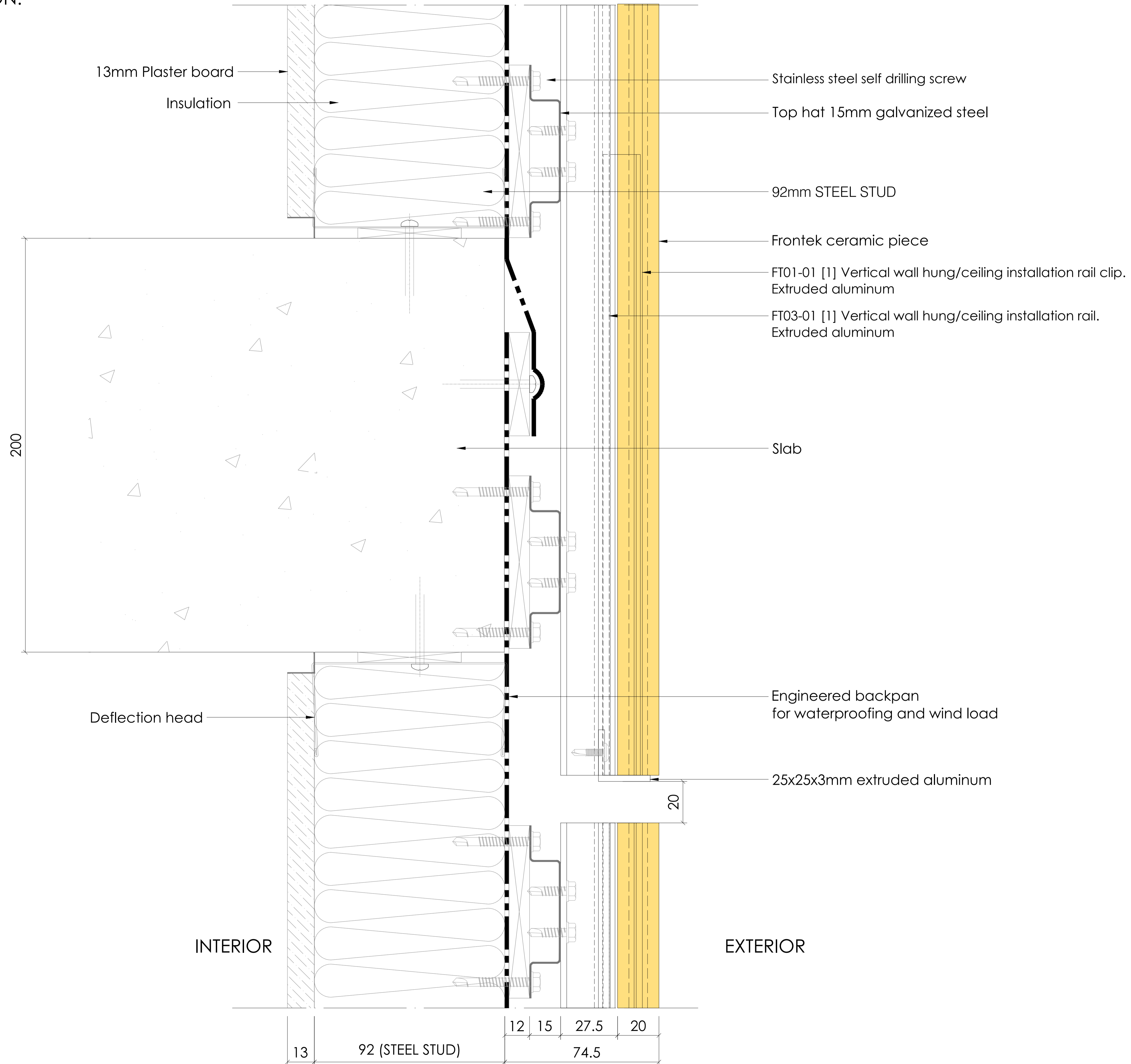

FOR INFORMATION

COPYRIGHT

These designs, details and/or specifications and the Copyright Therein, remain the property of **Frontek Australia.** and shall not be divulged in any form whatsoever without written permission of **Frontek Australia.**

All fixings sizes and types to be engineered by constructors

DRAWING DESCRIPTION
VERTICAL SECTION

FACADE TYPE
92 MM STUD WALL

FRONTEK SYSTEM
VERTICAL CONFIGURATION

DRAWN BY
BEATRIZ QUINTANA

FIRST DRAWN DATE 16/05/2018

REVIEWED BY
-

SCALE 1/20 SIZE A3

DRAWING NO. D102

frontek
cerámica tecnológica en fachadas

FRONTEK AUSTRALIA PTY LTD.
www.frontek.com.au
+61 2 9316 6818

Vertical Configuration STUD WALL

HORIZONTAL SECTION.
FLUSH FACADE DETAIL

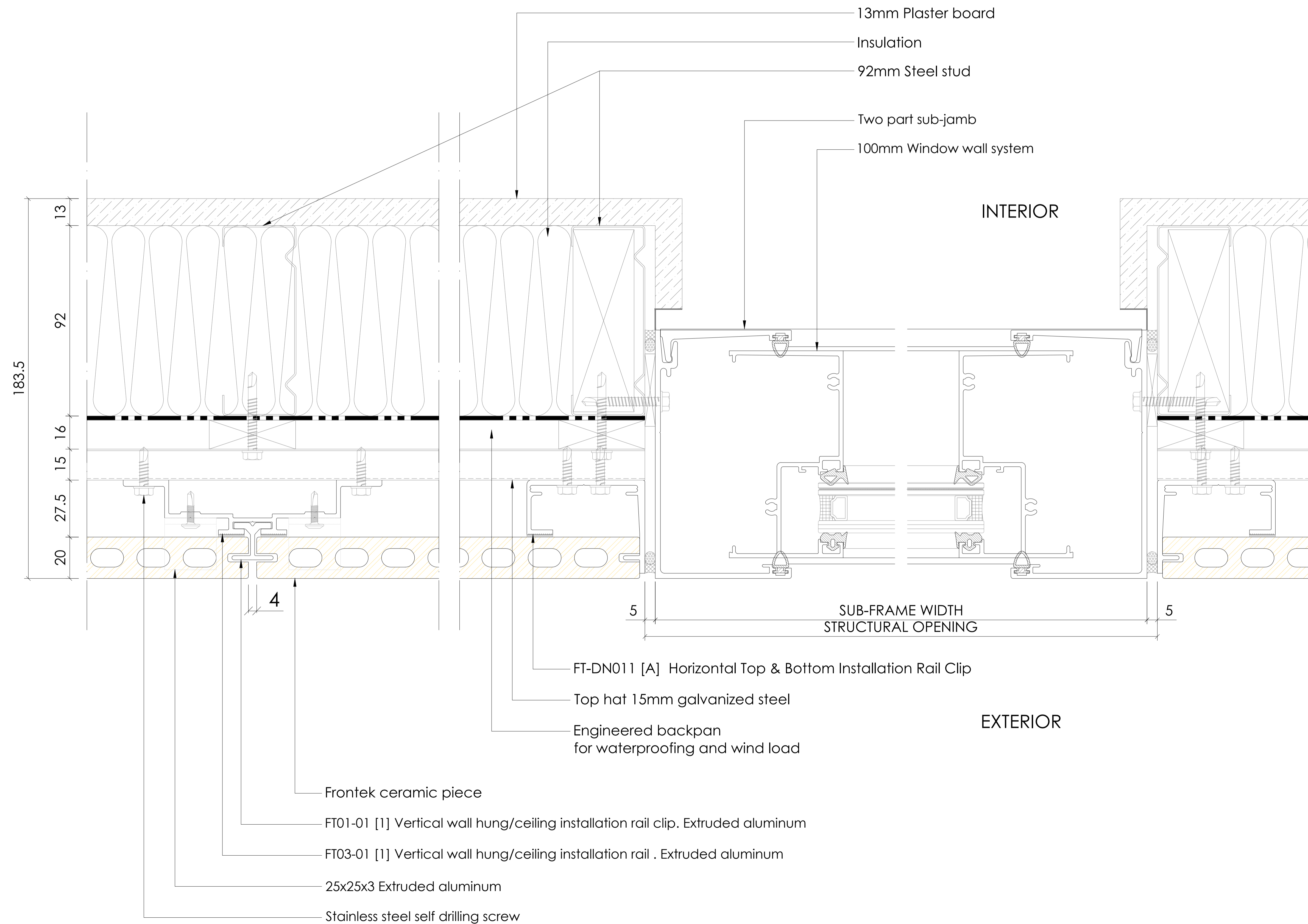

FOR INFORMATION

COPYRIGHT

These designs, details and/or specifications and the Copyright Therein, remain the property of **Frontek Australia.** and shall not be divulged in any form whatsoever without written permission of **Frontek Australia.**

All fixings sizes and types to be engineered by constructors

DRAWING DESCRIPTION
HORIZONTAL SECTION
FLUSH FACADE DETAIL

FACADE TYPE
92 MM STUD WALL

FRONTEK SYSTEM
VERTICAL CONFIGURATION

DRAWN BY
BEATRIZ QUINTANA

FIRST DRAWN DATE 16/05/2018

REVIEWED BY
-

SCALE 1/20 SIZE A3

DRAWING NO. D103

frontek
cerámica tecnológica en fachadas

FRONTEK AUSTRALIA PTY LTD.
www.frontek.com.au
+61 2 9316 6818

Vertical Configuration STUD WALL

HORIZONTAL SECTION.
REVEAL FACADE DETAIL

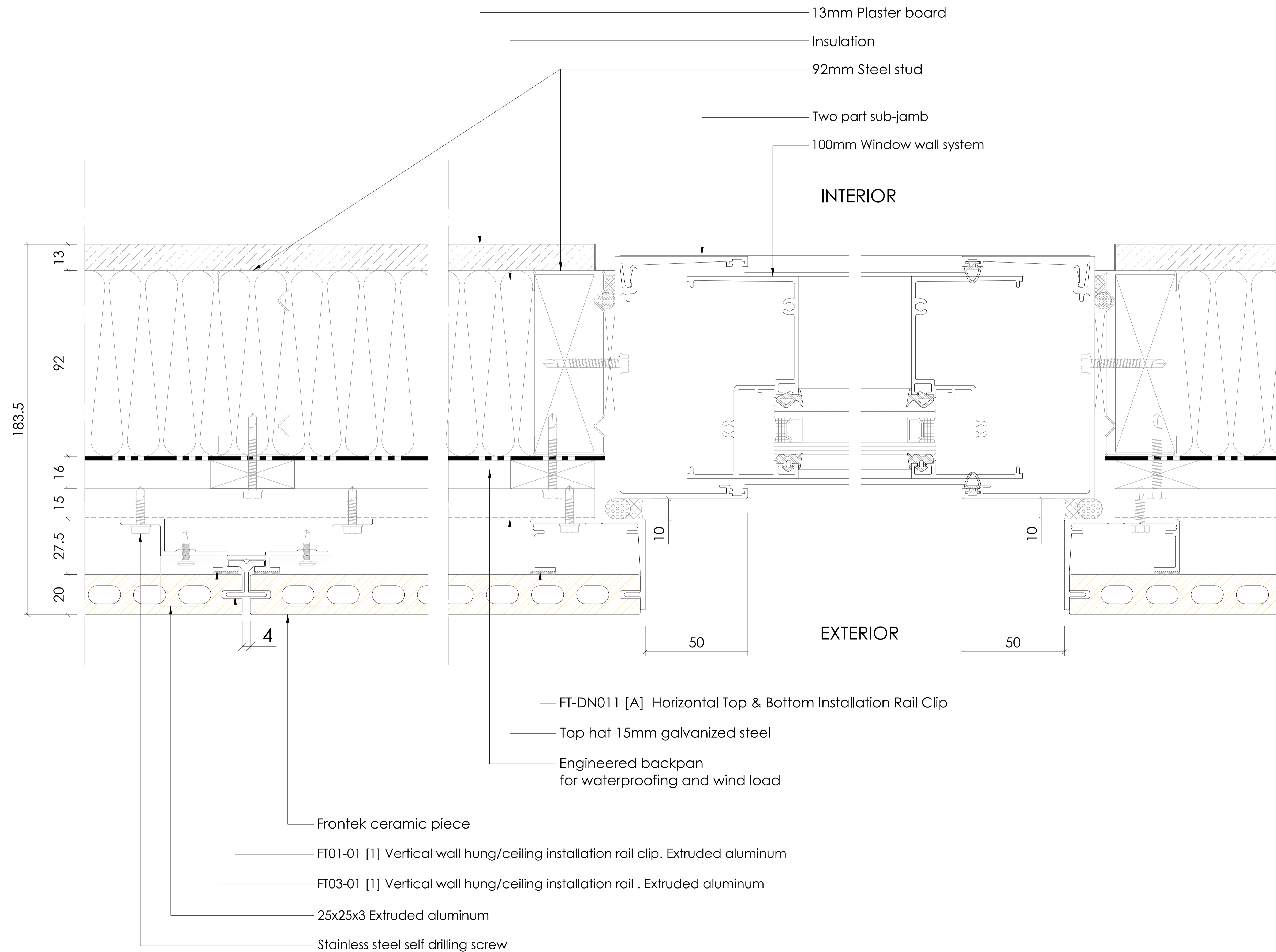

FOR INFORMATION

COPYRIGHT

These designs, details and/or specifications and the Copyright Therein, remain the property of **Frontek Australia.** and shall not be divulged in any form whatsoever without written permission of **Frontek Australia.**

All fixings sizes and types to be engineered by constructors

DRAWING DESCRIPTION
HORIZONTAL SECTION
REVEAL FACADE DETAIL

FACADE TYPE
92 MM STUD WALL

FRONTEK SYSTEM
VERTICAL CONFIGURATION

DRAWN BY
BEATRIZ QUINTANA

FIRST DRAWN DATE 16/05/2018

REVIEWED BY
-

SCALE 1/20 SIZE A3

DRAWING NO. D104

frontek
cerámica tecnológica en fachadas

FRONTEK AUSTRALIA PTY LTD.
www.frontek.com.au
+61 2 9316 6818

Vertical Configuration STUD WALL

HORIZONTAL SECTION. OUTSIDE CORNER.

FRONTEK MITER CUT

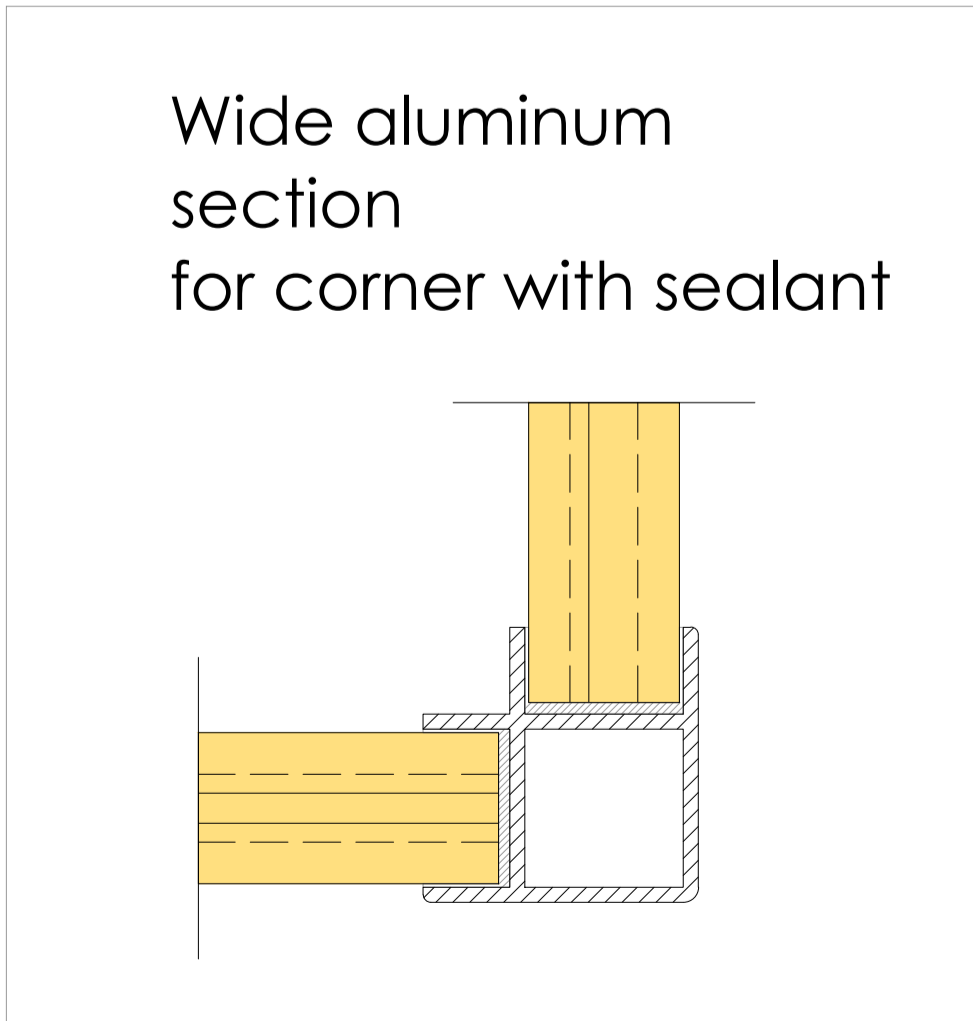
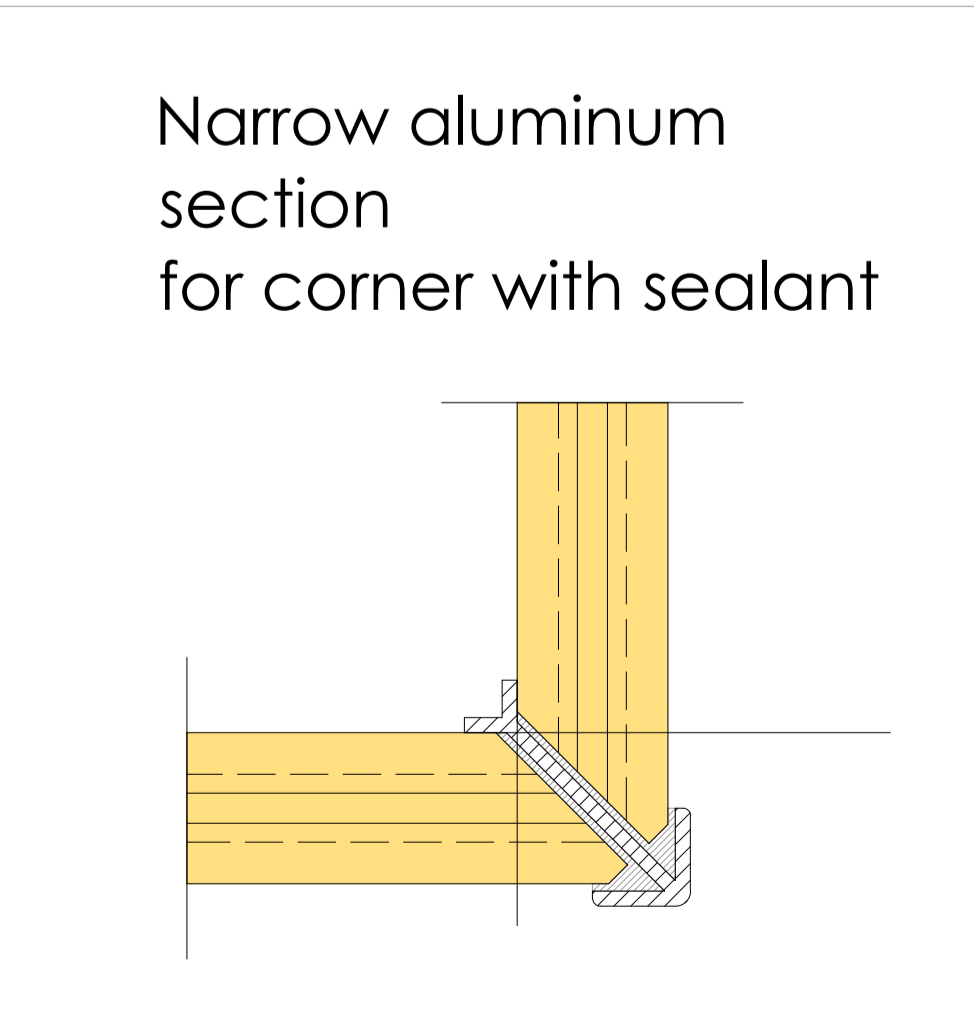
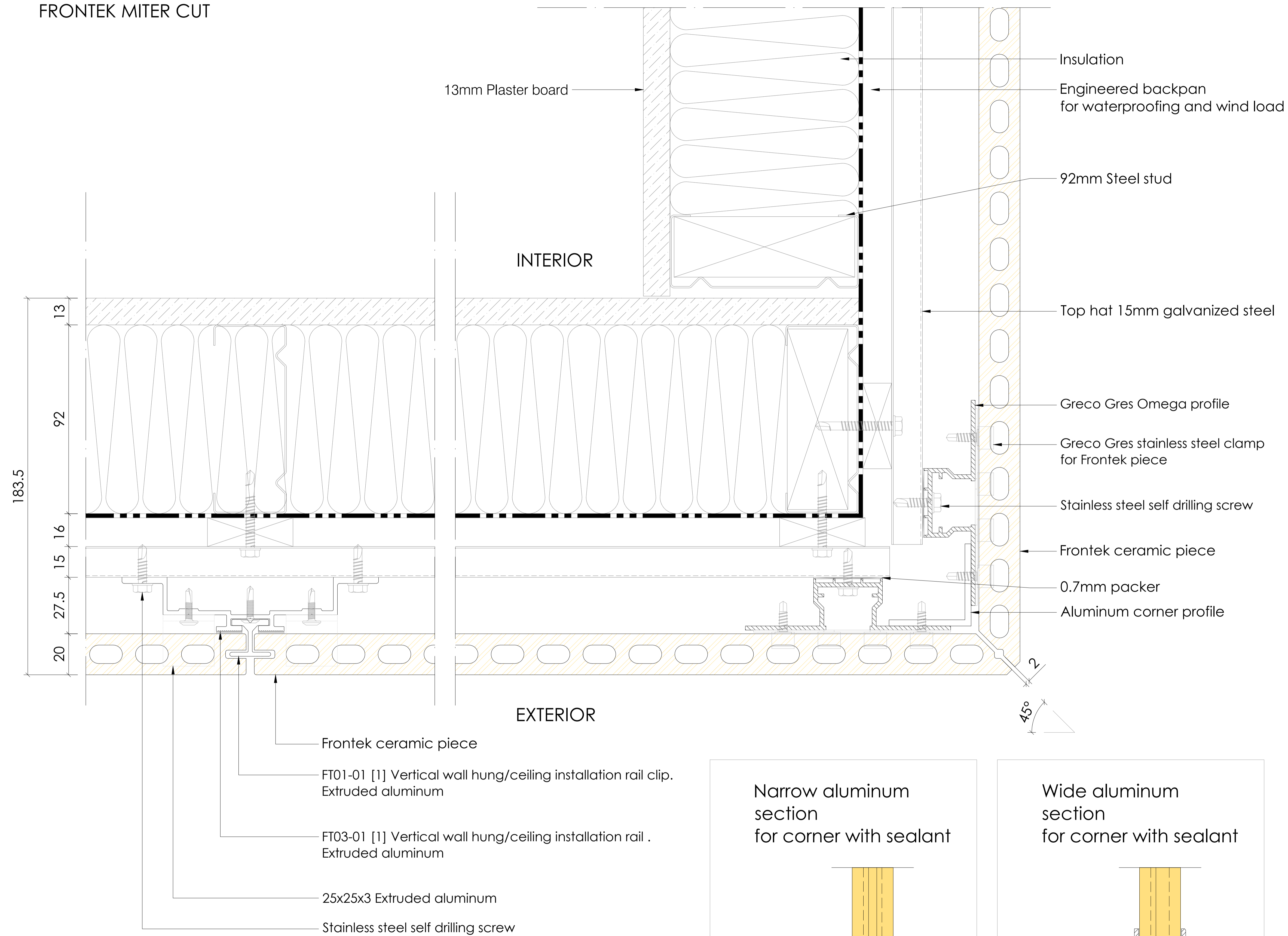

FOR INFORMATION

COPYRIGHT

These designs, details and/or specifications and the Copyright Therein, remain the property of **Frontek Australia.** and shall not be divulged in any form whatsoever without written permission of **Frontek Australia.**

All fixings sizes and types to be engineered by constructors

DRAWING DESCRIPTION
HORIZONTAL SECTION
OUTSIDE CORNER

FACADE TYPE
92 MM STUD WALL

FRONTEK SYSTEM
VERTICAL CONFIGURATION

DRAWN BY
BEATRIZ QUINTANA

FIRST DRAWN DATE 16/05/2018

REVIEWED BY
-

SCALE 1/20 SIZE A3

DRAWING NO. D105

frontek
cerámica tecnológica en fachadas

FRONTEK AUSTRALIA PTY LTD.
www.frontek.com.au
+61 2 9316 6818

Horizontal Configuration STUD WALL

HORIZONTAL SECTION. INTERIOR CORNER.

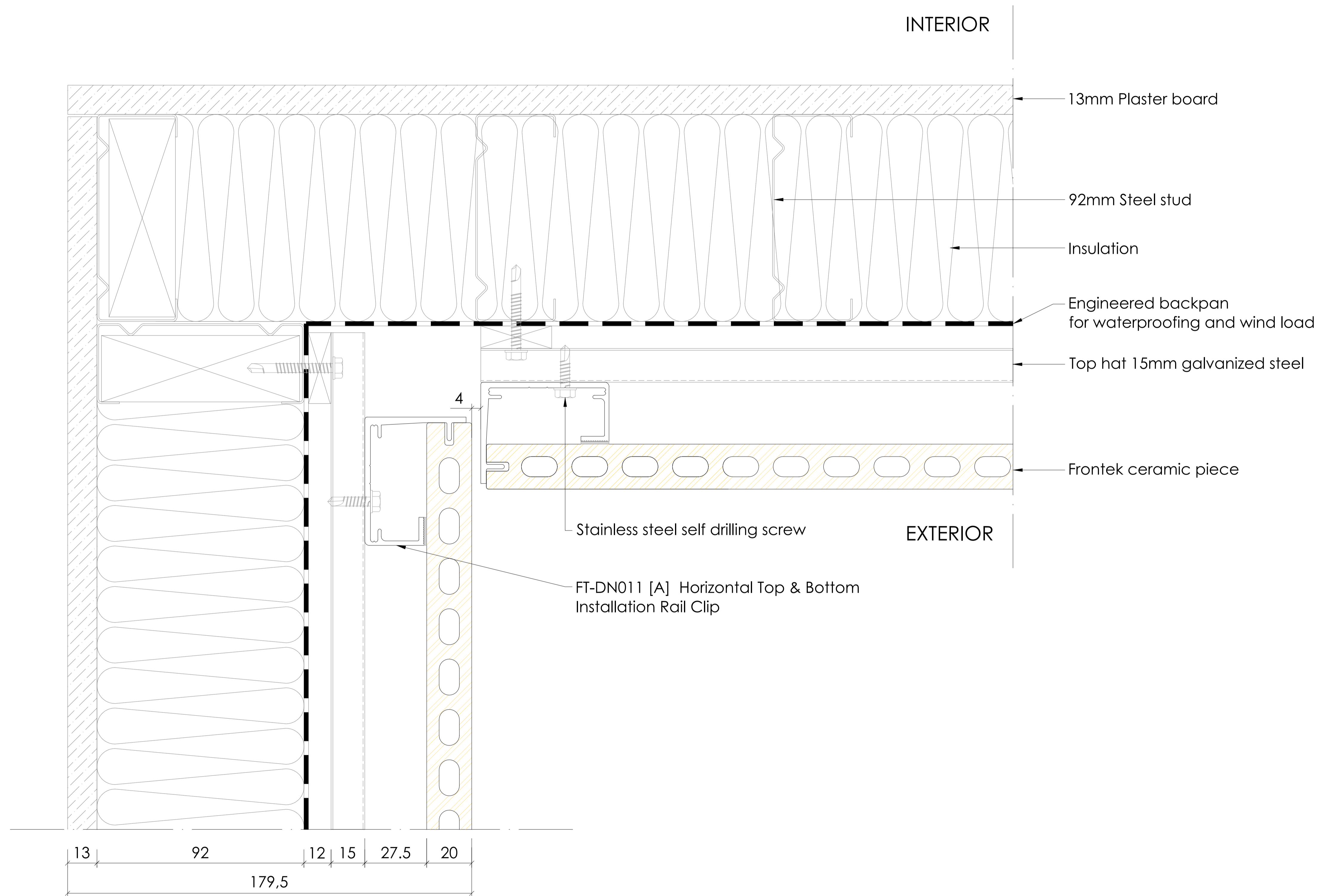

FOR INFORMATION

COPYRIGHT

These designs, details and/or specifications and the Copyright Therein, remain the property of

Frontek Australia.

and shall not be divulged in any form whatsoever without written permission of

Frontek Australia.

All fixings sizes and types to be engineered by constructors

DRAWING DESCRIPTION
HORIZONTAL SECTION
INTERIOR CORNER

FACADE TYPE
92 MM STUD WALL

FRONTEK SYSTEM
VERTICAL CONFIGURATION

DRAWN BY
BEATRIZ QUINTANA

FIRST DRAWN DATE 16/05/2018

REVIEWED BY
-

SCALE 1/20 SIZE A3

DRAWING NO. D106

frontek
cerámica tecnológica en fachadas

FRONTEK AUSTRALIA PTY LTD.
www.frontek.com.au
+61 2 9316 6818