

IMPORTANT : All INNOWOOD products must be installed in strict accordance with INNOWOOD'S current (at time of installation) "INSTALLATION MANUAL" and "CARE AND MAINTENANCE GUIDELINES" which can be downloaded from our website : www.innowood.com

Failure to comply with these documents may void warranty and result in an unsatisfactory outcome.

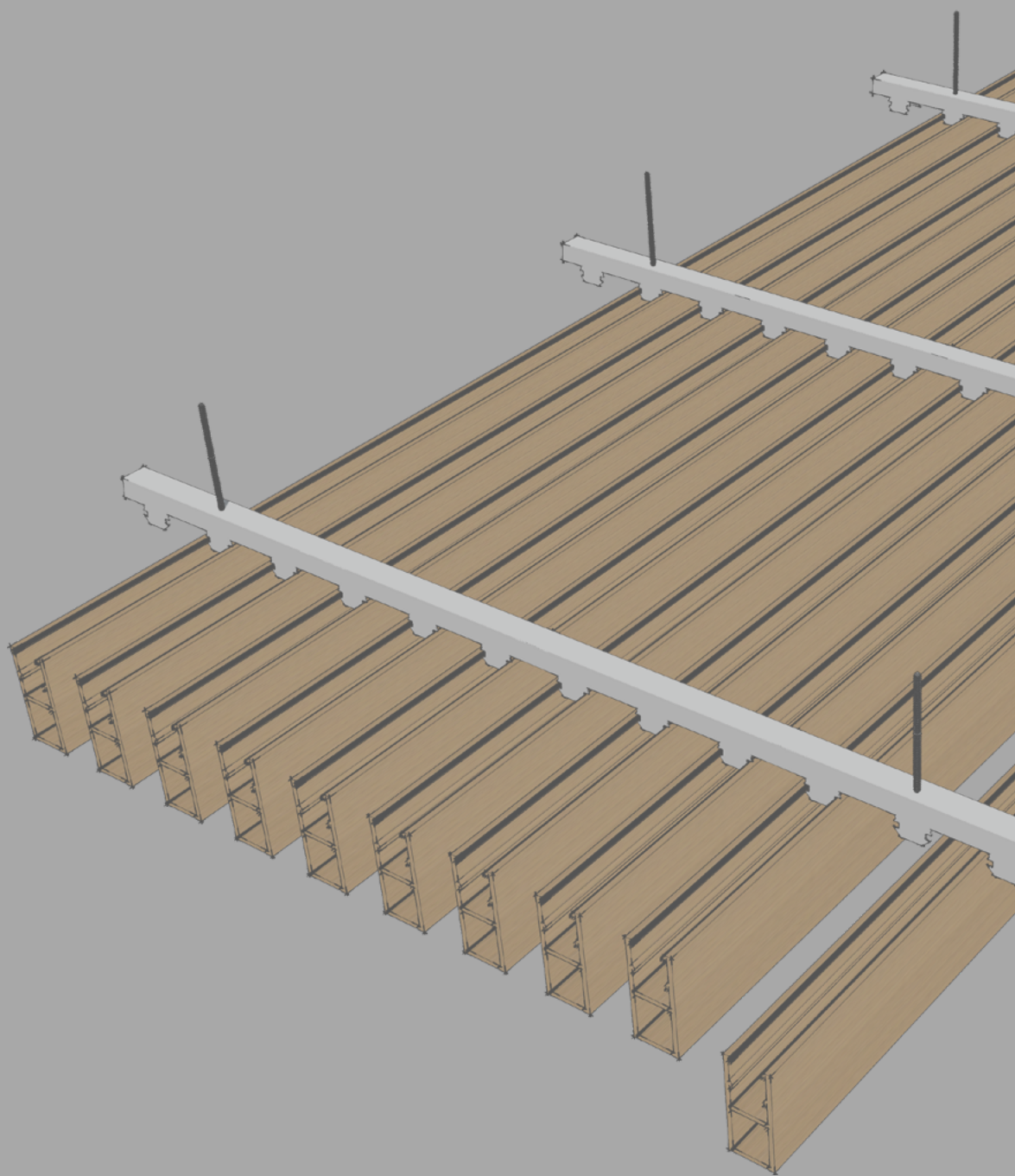

INNOCEIL

CONCEAL CLIP. SHIPLAP. SLATTED &
SUSPENDED CLICK ON FIXING
INSTALLATION MANUAL



BEFORE YOU COMMENCE

Please note that:

















































The Product is subject to natural variation* in finish as part of the manufacturing process. The purchaser or their installer/builder is responsible for inspecting, prior to installation, the colour, finish and size of the Product, identifying whether the Product has any other defect or manufacturing fault, and for ensuring the Product meets surface appearance and product specification requirements. Subject to the terms of our warranty, INNOWOOD is not liable for claims made after the installation of the Product that relate to surface appearance and product specification.

*INNOWOOD product is made predominantly from timber hardwood waste, colour will vary up to +/-20% according to the hardwood species used in its manufacture.

It is the responsibility of the specifier or other party to ensure that the information in this manual is appropriate for the intended application and further design detailing may have to be made for specific applications that fall outside the scope of the manual.

Information contained on this document is the copyright of INNOWOOD Australia Pty Ltd. Use or copying of this document in whole or in part without the written permission of INNOWOOD Australia is not permitted.

INNOCEIL PROFILES

CONCEAL CLIP & SHIPLAP FIXING							
SECTION							
PRODUCT CODE	CL14025	CL30025	CL14010	CL17012	CL20010	CL19212	
COVERAGE	140mm	300mm	120mm	170mm	180mm	175mm	
SPAN CENTRES*	450mm	450mm	450mm	450mm	450mm	450mm	
CONCEAL CLIP & SHIPLAP FIXING							
SECTION							
PRODUCT CODE	CL21923	CL26430	CL16728	CL27765	CL19519		
COVERAGE	195mm	240mm	148mm	250mm	175mm		
SPAN CENTRES*	450mm	450mm	450mm	450mm	450mm		
SUSPENDED CLICK ON & CLOCK IN							
SECTION							
PRODUCT CODE	CL05020	CL07030	CL07030B	PS05050	PS07550	PS10050	PS15050
COVERAGE	20mm	30mm	30mm	50mm	50mm	50mm	50mm
SPAN CENTRES*	450mm	450mm	450mm	450mm	450mm	450mm	450mm
SLATTED							<p>Note: Guide only, span is dependent on region and wind load, please confirm with structural engineer prior to installation.</p>
SECTION							
PRODUCT CODE	SS05050	FS04535	FS06535	RS10050	RS15050	RS12530	
COVERAGE	50mm	45/35mm	36/65mm	50/100mm	50/150mm	30/125mm	
SPAN CENTRES*	450mm	450mm	450mm	450mm	450mm	450mm	

Installation Tips and Requirements

INNOWOOD products can be worked with ordinary woodworking tools such as:

Circular Saw	Cordless Drill
Crosscut Mitre Saw	Level & Chalk Line
Carpenters Square	Tape Measure

NOTE:

To ensure long-term performance, we recommend that a professional trade person carry out the installation. The installation MUST be carried out in accordance with these instructions including the use of all trims and accessories.

Site storage & Product Handling

- INNOWOOD boards should not be stored in the open or covered or wrapped with plastic sheet. INNOWOOD boards are a finished product, do not dump or drop when loading or unloading. Always handle with care.
- INNOWOOD boards should be stored under cover and protected from the elements (including direct sunlight and rain) until ready to install. Remove any plastic wrap including shrink wrap and store on a dry and flat surface supported at max 450mm centres.
- When removing INNOWOOD boards from the pack, do not slide boards against each other, lift the boards and set them down carefully.
- INNOWOOD boards should be carried on their edge for better support.
- When handling INNOWOOD boards take care to avoid scratches, nicks and other damage to the boards.

Thermal movement

Any wood based products will expand and contract with changes in temperature. The amount of expansion varies according to the amount of change in temperature. Although thermal movements are reversible, these movements due to temperature change may vary by up to 2mm per meter.

INNOWOOD boards that have been exposed to direct sun for several hours, prior to installation will have expanded more than boards left in the shade. It is important to maintain an average consistent temperature for all boards as they are being installed.

Avoid installing in full sun if ambient temperature is above 30°C. Ensure the boards are kept out of the sun until installed to limit the boards expansion prior to installation. INNOWOOD products can tolerate a temperature range from -20°C to +65°C.

If the product is to be used in an environment outside of this temperature range, please consult INNOWOOD.

Please bear in mind that:

- Where INNOWOOD boards are to be screw fixed, clearance holes must be pre-drilled before fixing (both INNOWOOD boards and accessories).
- The clearance hole to be drilled must be slightly greater than the outside screw thread diameter.
- Screws must be minimum 15mm but maximum 25mm away from board edges (unless noted otherwise)
- INNOWOOD products must not be used for any structural purpose.
- The cut surface must be sealed with a layer of protective coating such as a water based deck sealer before installation.
- When exposed to direct sunlight, surface temperature may be significantly hotter than ambient temperature.

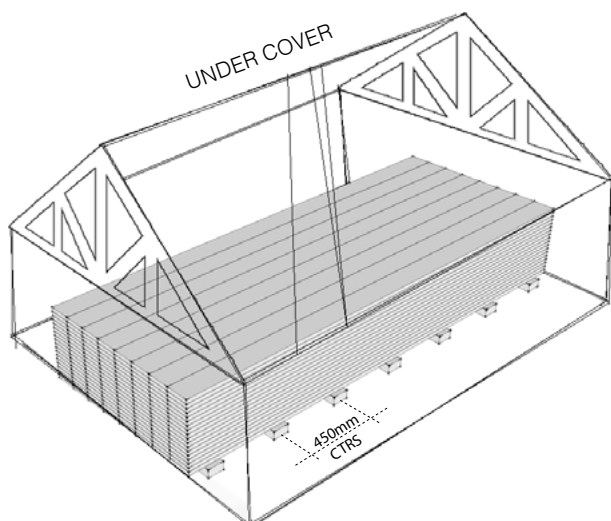

Framing

INNOCEIL systems utilise various common framing formats however, this manual cannot address all possible solutions, further design detailing may have to be made for specific applications that fall outside the scope of the manual.

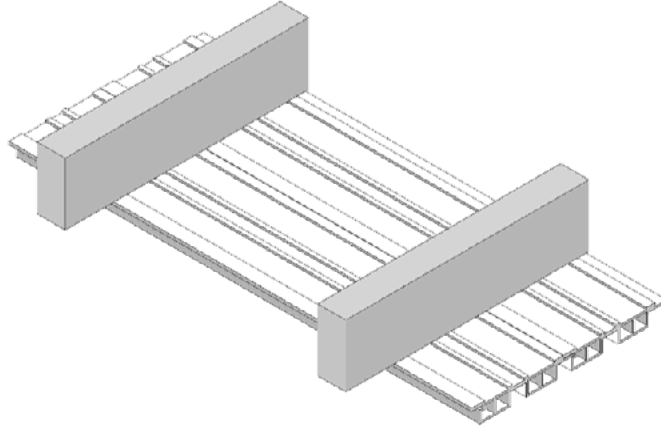

A. SCREW FIXED DIRECTLY TO TIMBER/STEEL FLOOR/CEILING JOISTS

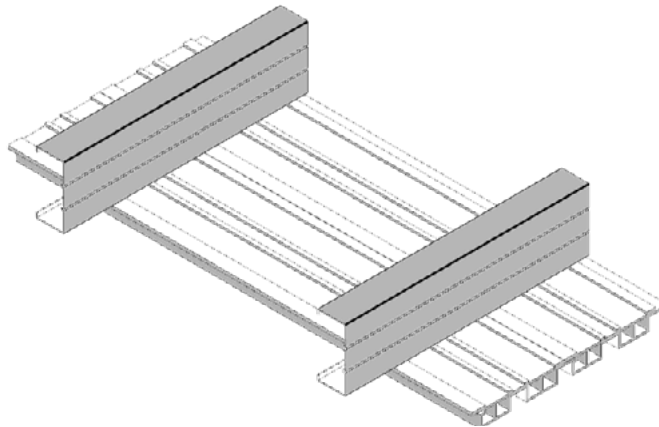

B. SCREW FIXED DIRECTLY TO LIPPED STEEL C-STUD

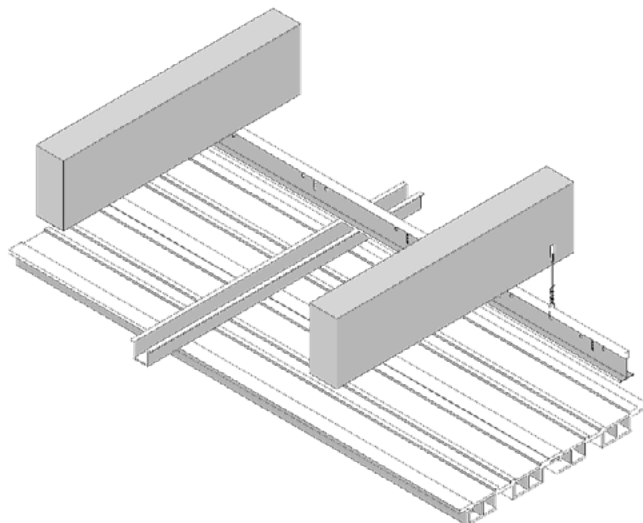

C. SCREW FIXED TO SUSPENDED CONCEALED METAL GRID UNDER FLOOR/CEILING JOISTS

Framing construction requirements

INNOWOOD ceiling may be fixed to seasoned timber joists or to a proprietary structural system.

Joist spacing for INNOWOOD ceiling is nominally set at 450mm centres when used as internal lining and 300mm max centres when used as soffit in urban and non-cyclonic wind load areas. For higher wind-load areas reducing batten spacing may be required. All boards must span across a minimum of 3 joists.

As with all ceiling products the adequacy of the proposed installation should always be checked by a qualified engineer.

Battens must have a face no less than 45mm for timber and 35mm for steel.

Where butt joints occur, double joists must be set.

Timber framing

The joints between posts, bearers and joists need to be able to transfer load efficiently through the structure, refer to AS1684 for design of these elements.

It is important to use adequately seasoned timber to minimise shrinkage and associated building movement, which may damage the soffit system.

Steel framing

Steel framing must comply with AS/NZS 4600: Cold-Formed Steel Structure or AS 3623: Domestic Metal Framing.

Where steel framing members are specified, use only corrosion resistant galvanized steel framing. Specific instructions for fixing to steel frames are included where appropriate.

Screws

Screws must comply with AS 3566 Self Drilling Screws for the Building and Construction Industries.

Screws must have a minimum Class 3 corrosion resistance, suitable for external applications in mild, moderate industrial and marine environments and Class 4 or stainless steel for severe environments.

Screws with class 1 or 2 corrosion resistance may be used for internal use depending on the individual application.



Wafer Head



Countersunk Head



Decking/Type 17

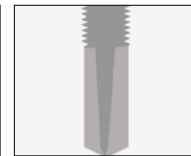

Self-drilling

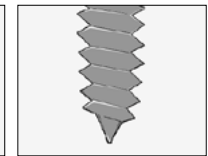

Self-tapping

INSTALLATION CL14025 (Note: this install detail is also applicable to WC14025.)

CONCEAL CLIP FIXING

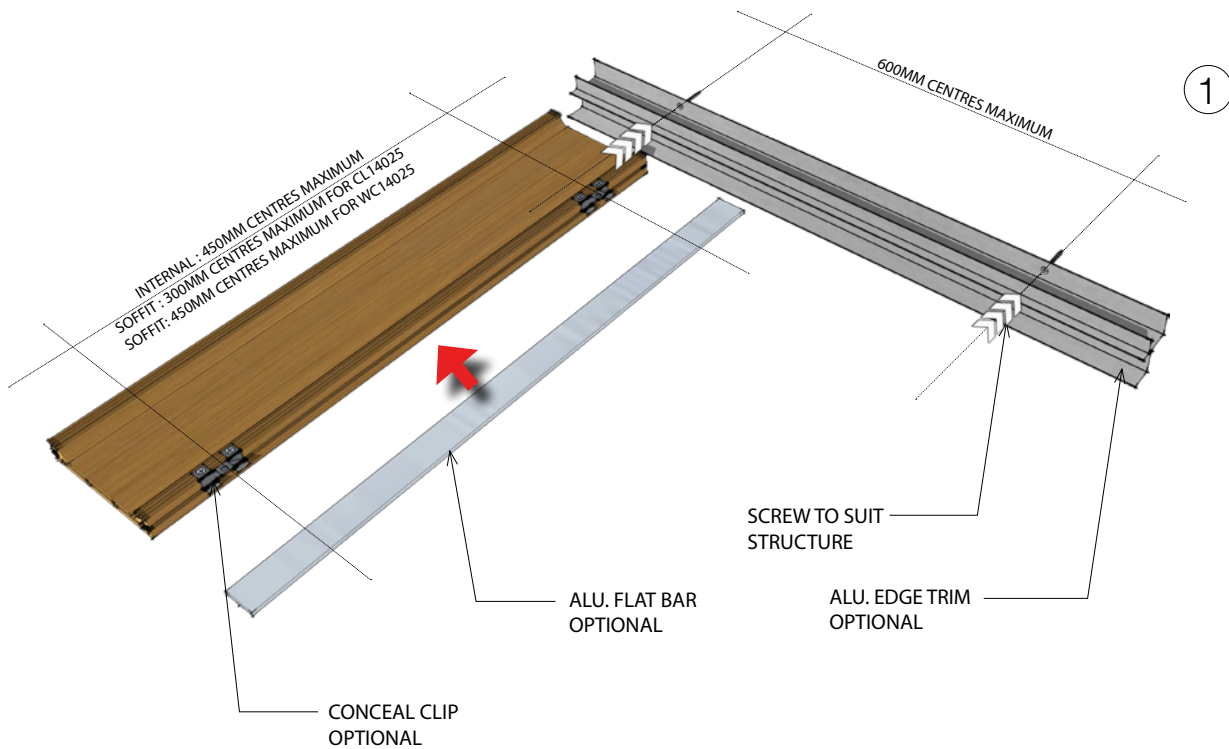

1. Use a string, spirit or laser level to establish the starting point of the ceiling. Screw fix aluminium starter and ensure the screw head is flush with starter surface to allow ceiling board to fit in later.
2. If Concealed Clip option is used, then make sure that the clip is screwed to boards prior to putting the next joining board.
3. Joists span is set to no more than 450mm centres for internal application, 300mm centres for soffit using CL14025 and 450 centres for Soffit using WC14025. Paint the starter to match the colour of ceiling board if necessary. Face fixing through ceiling board is an alternative solution without using starter.
4. Position the first ceiling board into the groove of the starter board and temporarily hold it in place. Ensure the clip is properly clipped together with ceiling board and use a flat head screw to fix the clip into the back-structure.

NOTE

- Pre-drilling is essential.
- All screws are minimum 15mm but maximum 25mm away from board edges.
- This install detail is also applicable to WC14025.

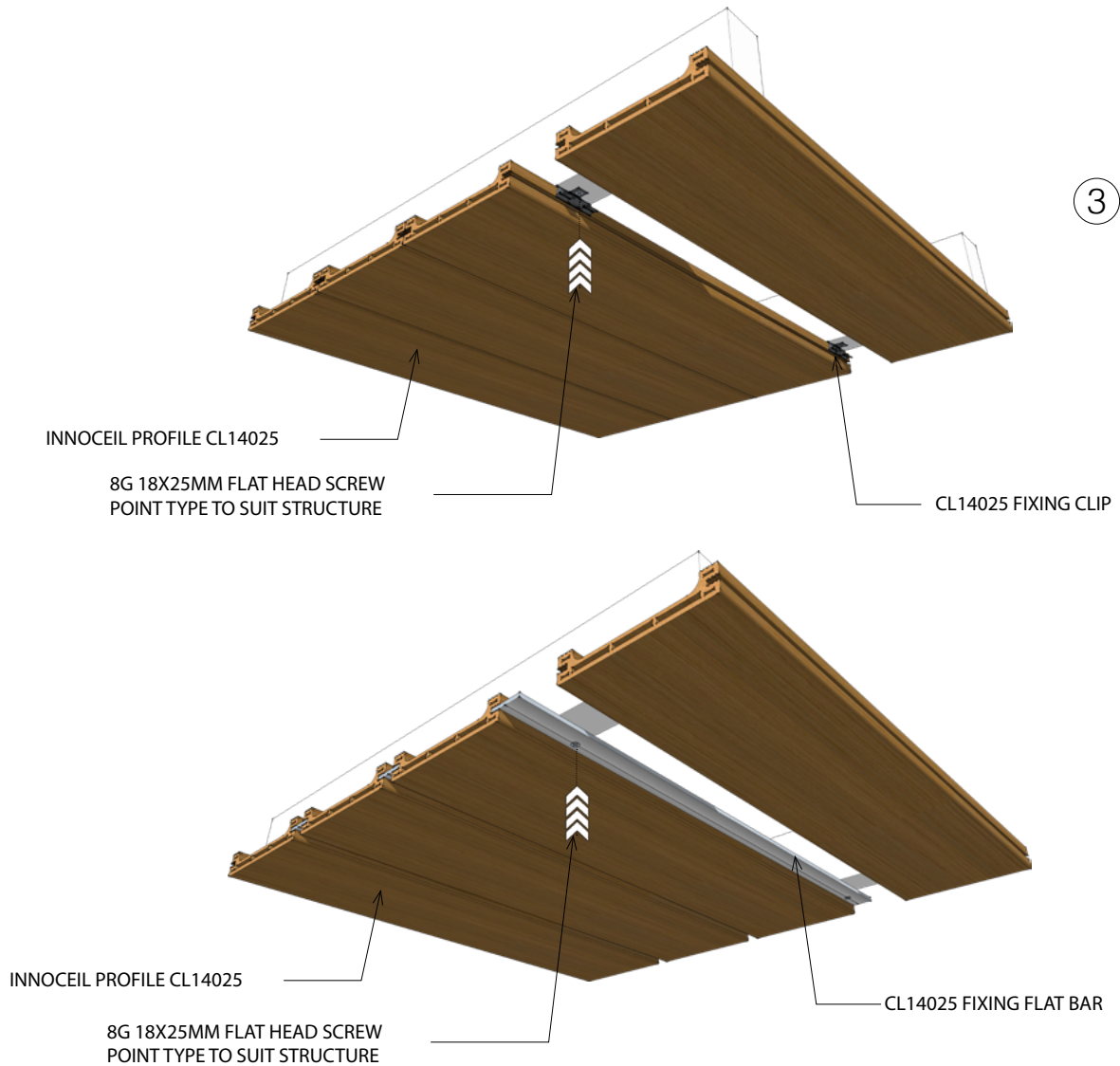

3. Position the second ceiling board into the clip fixed in step 2, ensure the ceiling board and clips are properly clipped together.

4. Repeat Step 2 and Step 3 until the ceiling is fully completed. Use the aluminium starter or appropriate cornice to finish off if necessary.

SHIPLAP FIXING

Please note that the following instruction is also applicable for CL14010/CL16728/CL21923/CL27765/CL26430/CL200210/CL19212/CL19519.

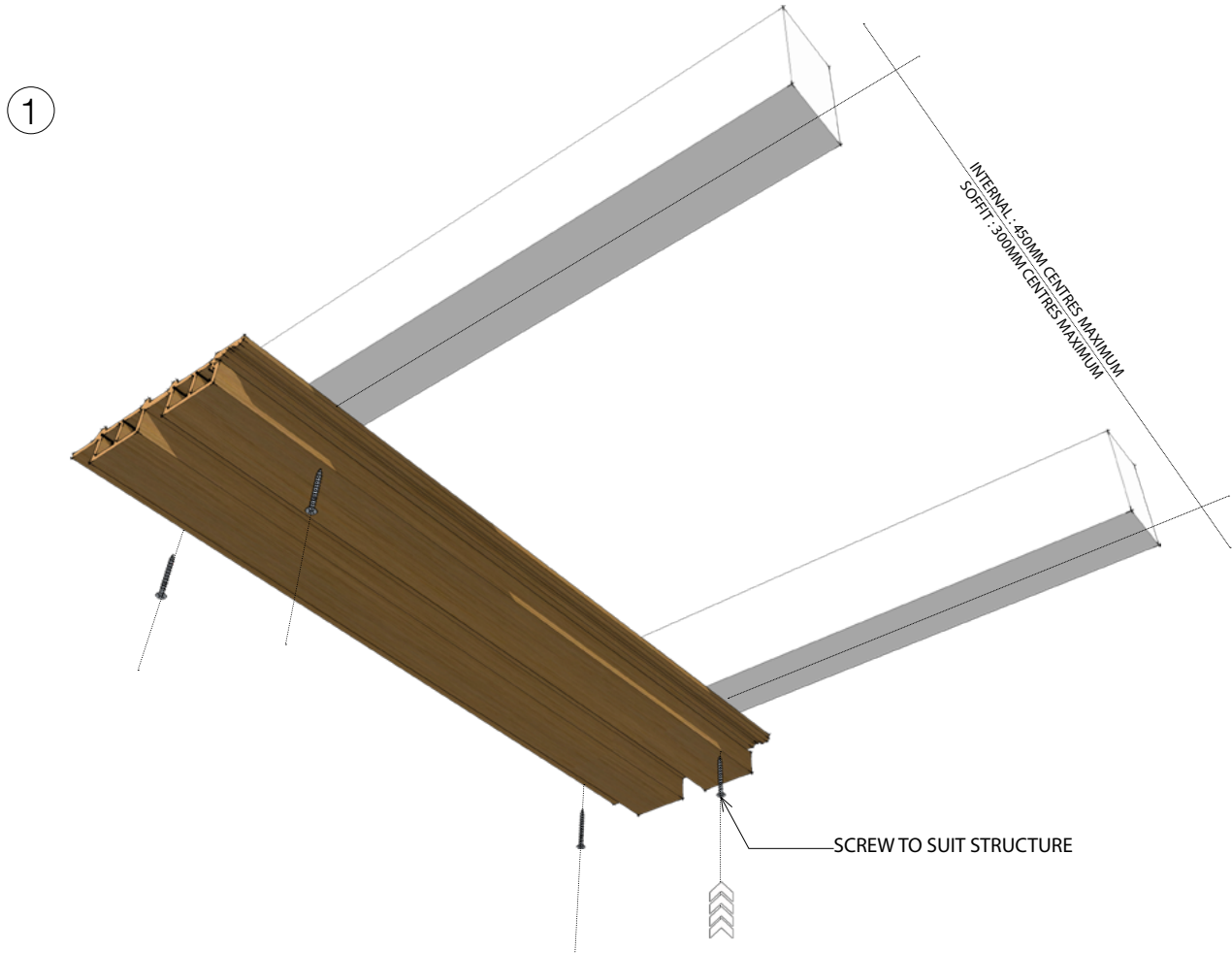

1. Use a string, spirit or laser level to establish the starting point of the ceiling. Use wafer head screws to fix the first ceiling board through the edge on both sides, be careful not to break the tongue of the starting board.
 - 1a. Joists span is set to no more than 450mm centres for internal application and 300mm centres for soffit.
 - 1b. Ensure the screw head is flush with board surface to allow the adjacent board to slide in.

NOTE

- Pre-drilling is essential.
- All screws are minimum 15mm to 25mm away from board edges.

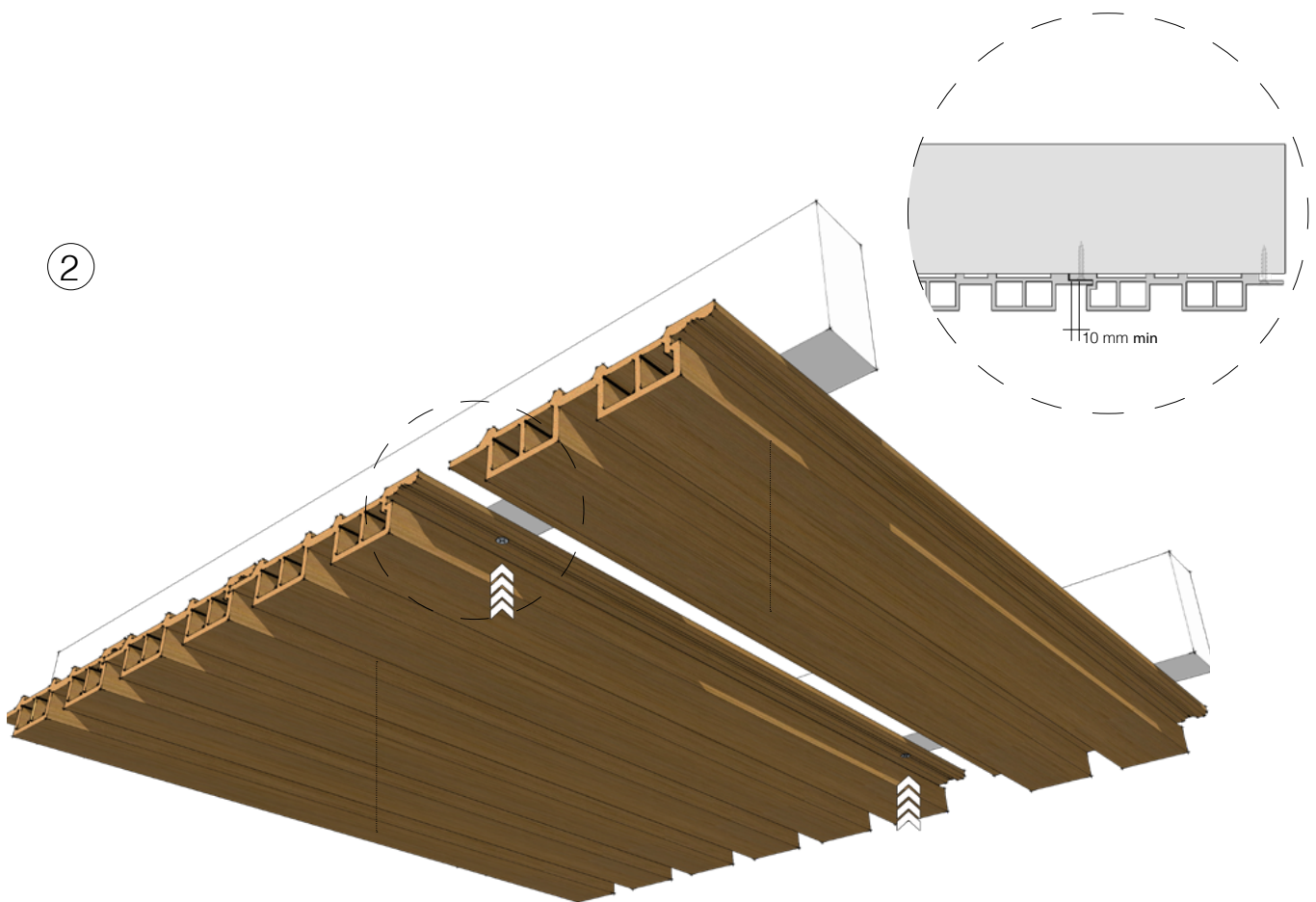

2

2. Position the second ceiling board into the groove of the first board and temporarily hold it in place.

2a. Use wafer head screw to screw fix the second board onto the back-structure.

2b. Repeat this step until the ceiling is fully installed. Use appropriate cornice to finish off if necessary.

NOTE

- Pre-drilling is essential.
- All screws are minimum 15mm to 25mm away from board edges.

SHIPLAP FIXING

Please note that the following instruction is also applicable for CL14010/CL16728/CL21923/CL27765/CL26430/CL200210/CL19212/CL19519.

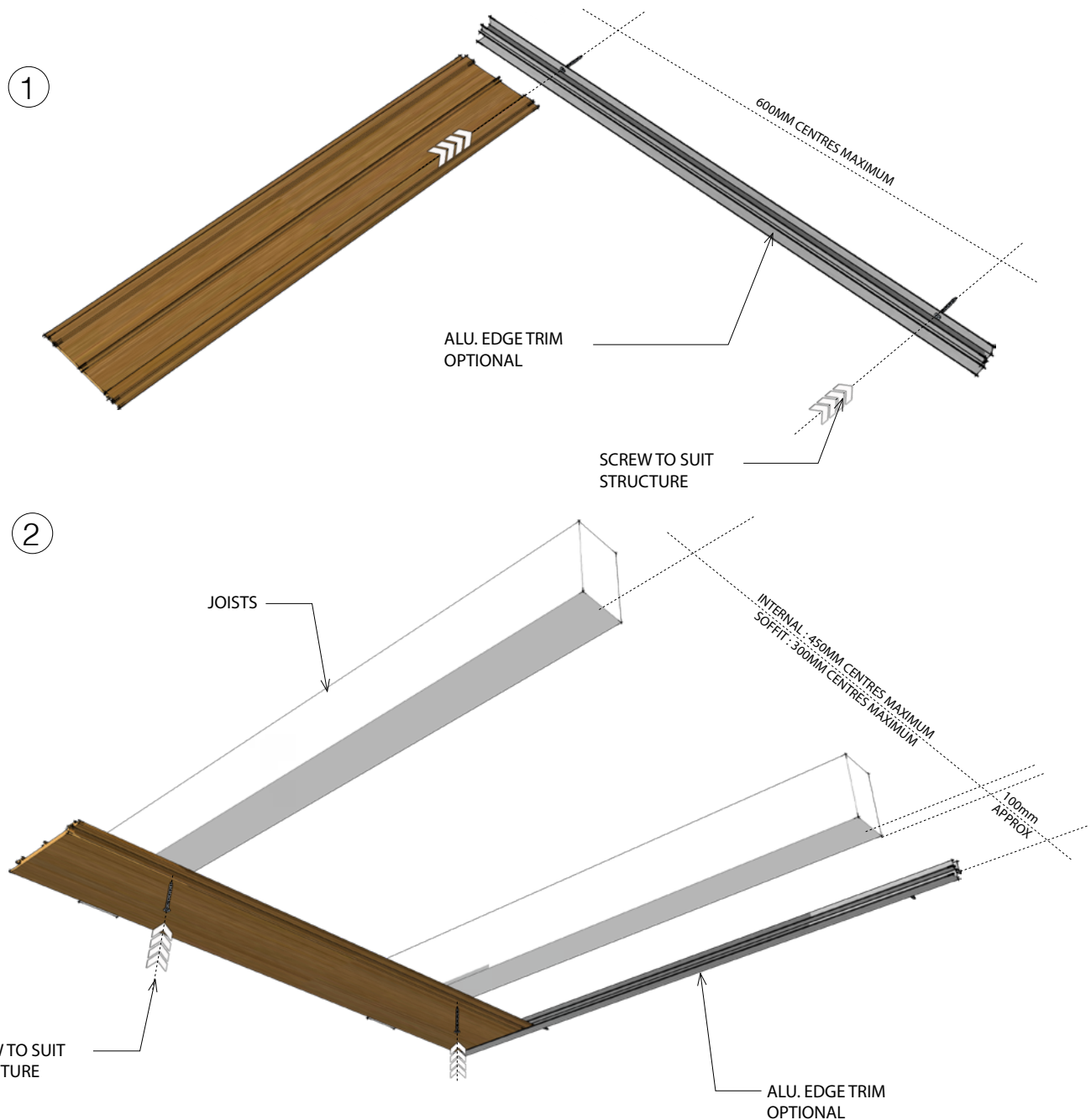

1. Use a string, spirit or laser level to establish the starting point of the ceiling. Use wafer head screws to fix the first ceiling board through the edge on both sides, be careful not to break the tongue of the starting board.
2. Joists span is set to no more than 450mm centres for internal application and 300mm centres for soffit. Ensure the screw head is flush with board surface to allow the adjacent board to slide in.

VENTILATION - Shiplap & Conclead Clip Fixing

INNOWOOD Soffit/Ceiling requires air flow through the cavity from cornices which is achieved via openings around corners of the installation. During installation, it is necessary to use minimum 10mm packing behind the top hats/battens to allow the air to flow behind or a 5-10mm gap between the boards and the wall should be observed.

Depending on the projects requirements and situation one of the following examples should be followed for the installation.

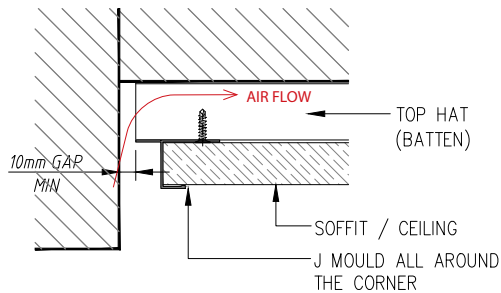

EXAMPLE 1

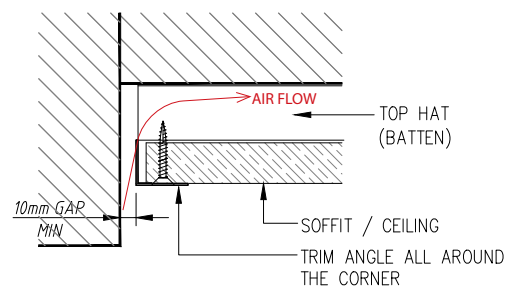

EXAMPLE 2

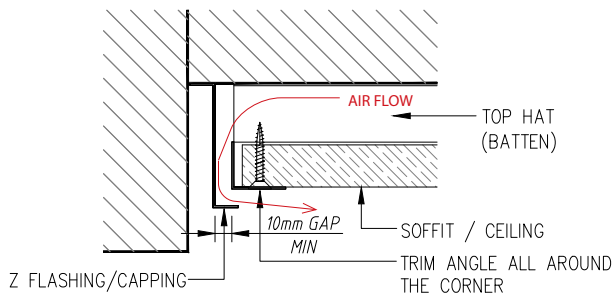

EXAMPLE 3

FIRST BOARD STARTING DETAIL WITH TWO PIECE J-TRIM (Castellated panel)

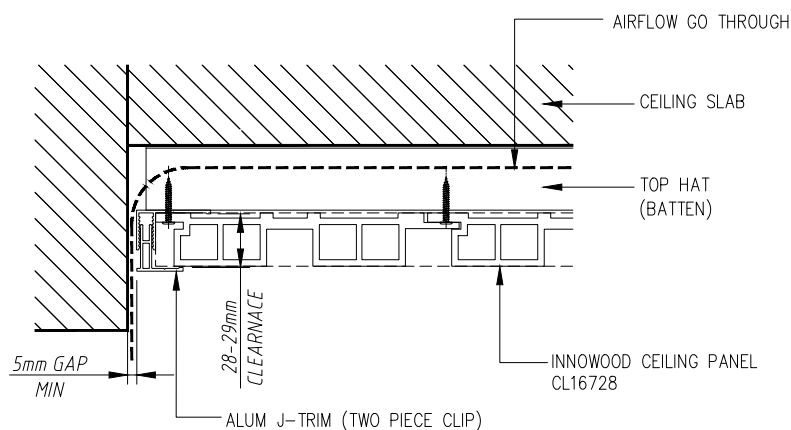

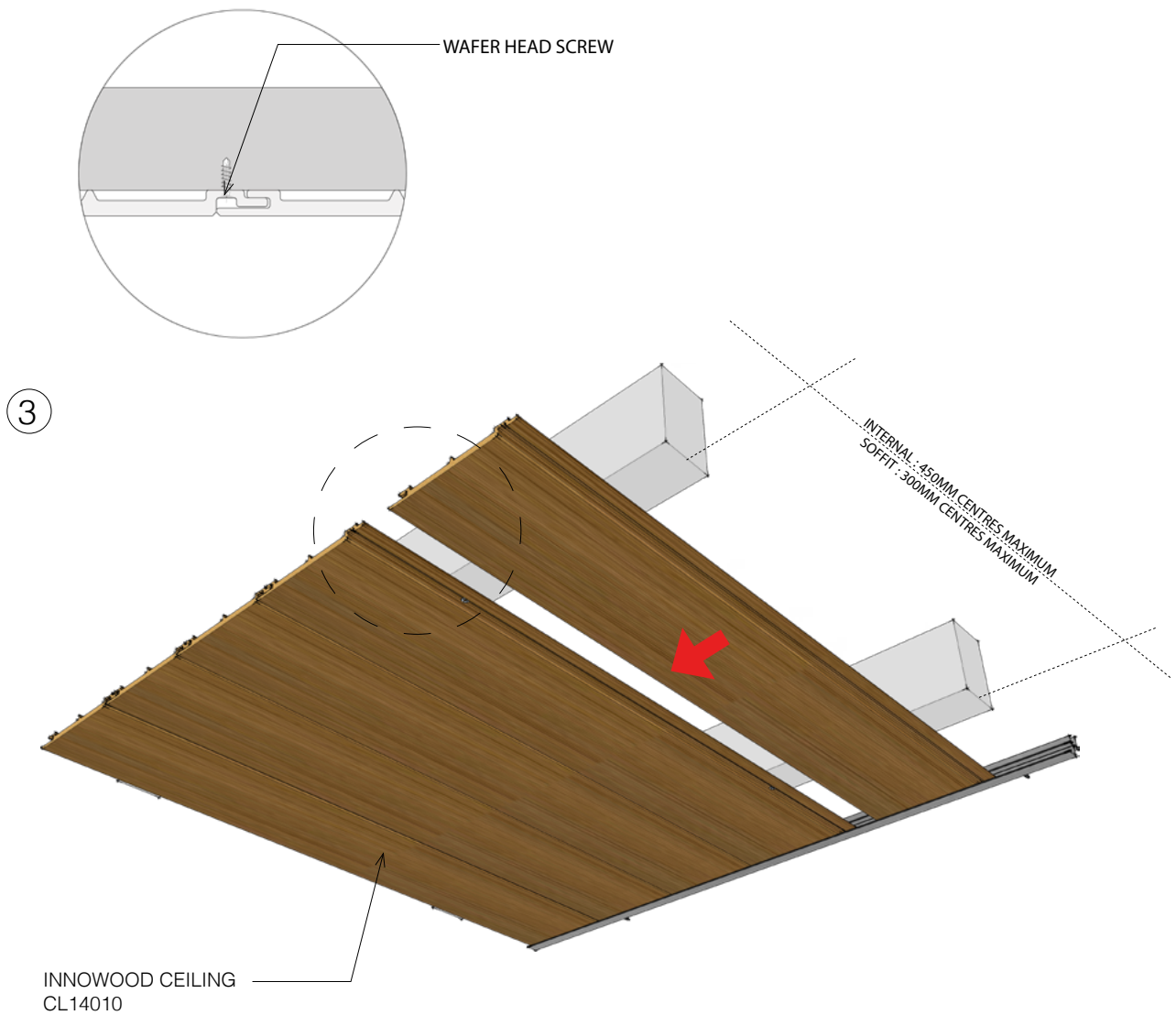

3. Position the second ceiling board into the groove of the first board and temporarily hold it in place. Use wafer head screw to screw fix the second board onto the back-structure.
- 3a. Repeat this step until the ceiling is fully installed. Use appropriate cornice to finish off if necessary.

LOCK-IN CEILING FIXING

The following instructions are applicable for PS05050 / PS07550 / PS10050 / PS15050.

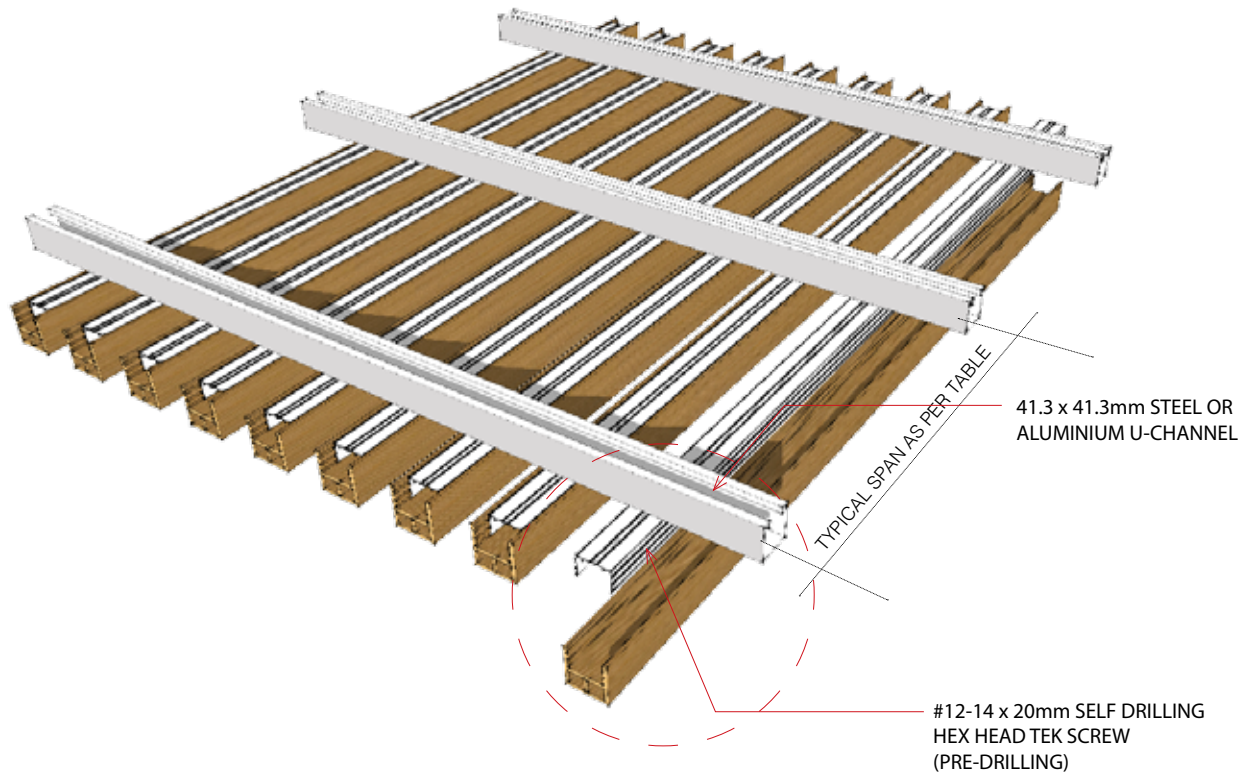

1. Use an appropriate spacing jig to define the gap between each Slatted Fixing Ceiling batten.
2. Fix the aluminium clip to the U-Channel (or similar structural support) from the face individually.

NOTE

- Pre-drilling is essential.
- All screws are minimum 15mm to 25mm away from the board edges.
- Aluminium clip must be 20-30mm shorter than batten at each end.





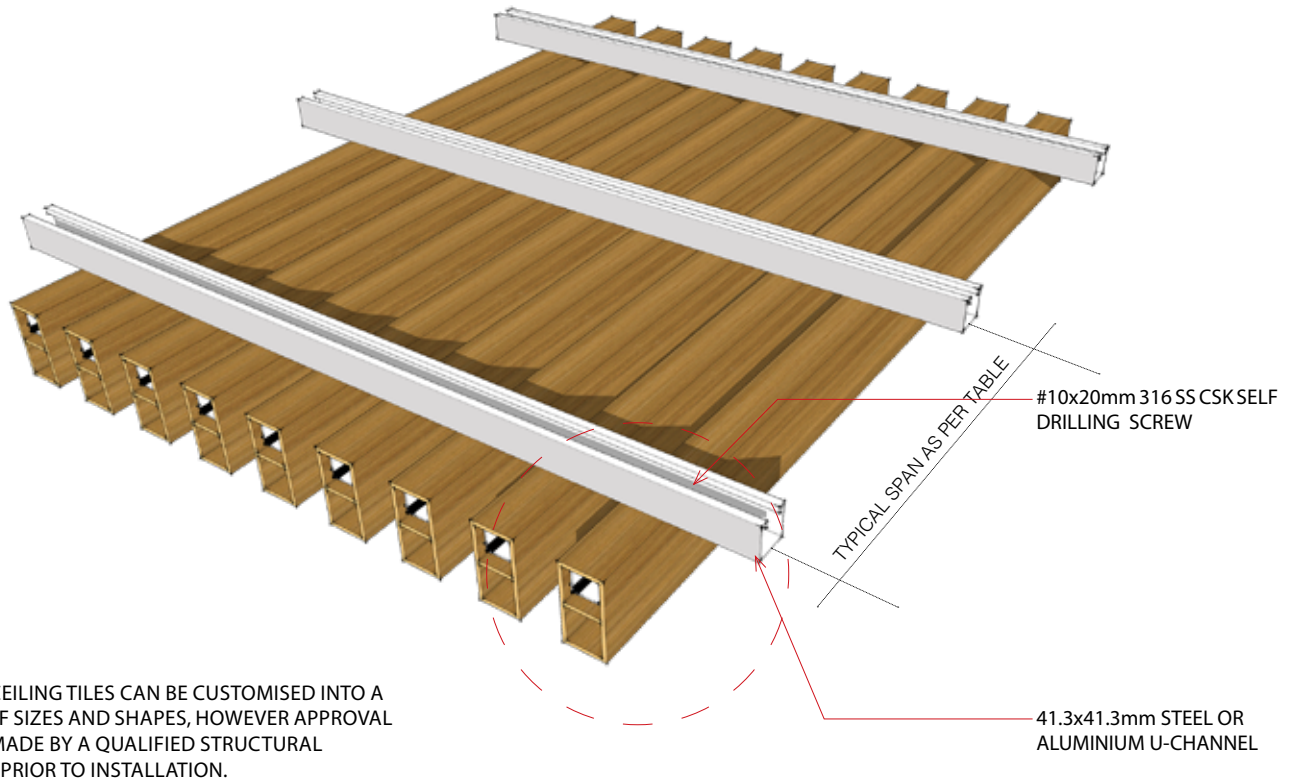

SLATTED FIXING

Please note that the following instruction is also applicable for FS04535 / FS06535 / SS05050 / RS10050 / RS15050 / RS12530.



SLATTED CEILING TILES CAN BE CUSTOMISED INTO A VARIETY OF SIZES AND SHAPES, HOWEVER APPROVAL MUST BE MADE BY A QUALIFIED STRUCTURAL ENGINEER PRIOR TO INSTALLATION.

Fixing Span with Aluminium Insert / Stiffener:

	FS04535	FS06535	FS06535	SS05050	SS10050	SS15050
Aluminium Inserts/ Stiffener Size	45 x 35	50 x 35	50 x 35	39 x 39	39 x 39	39 x 39
Aluminium Inserts/ Stiffener Code No.	 AL4535	 AL5035	 AL5035	 AL3939	 AL3939	 AL3939
Maximum Fixing Horizontally Span	1600mm	2000mm	2700mm	2000mm	2000mm	2000mm

* Based on a single span, if larger spans are required please consult INNOWOOD.

1. Use an appropriate spacing jig to define the gap between each Slatted Fixing Ceiling batten.
2. Pre-drill screw fix the battens with U-Channel (or similar structural support) and screw fix the insert and battens from the rear individually.

NOTE

- Pre-drilling is essential.

ALTERNATIVE FIXING DETAILS FOR INTERNAL CEILING SYSTEMS

Spans between adjacent fixing points of C-channels will vary depending on type of channels, types of profiles and gaps between adjacent profiles. Please consult INNOWOOD for confirmation of typical fixing spans of C-channels.

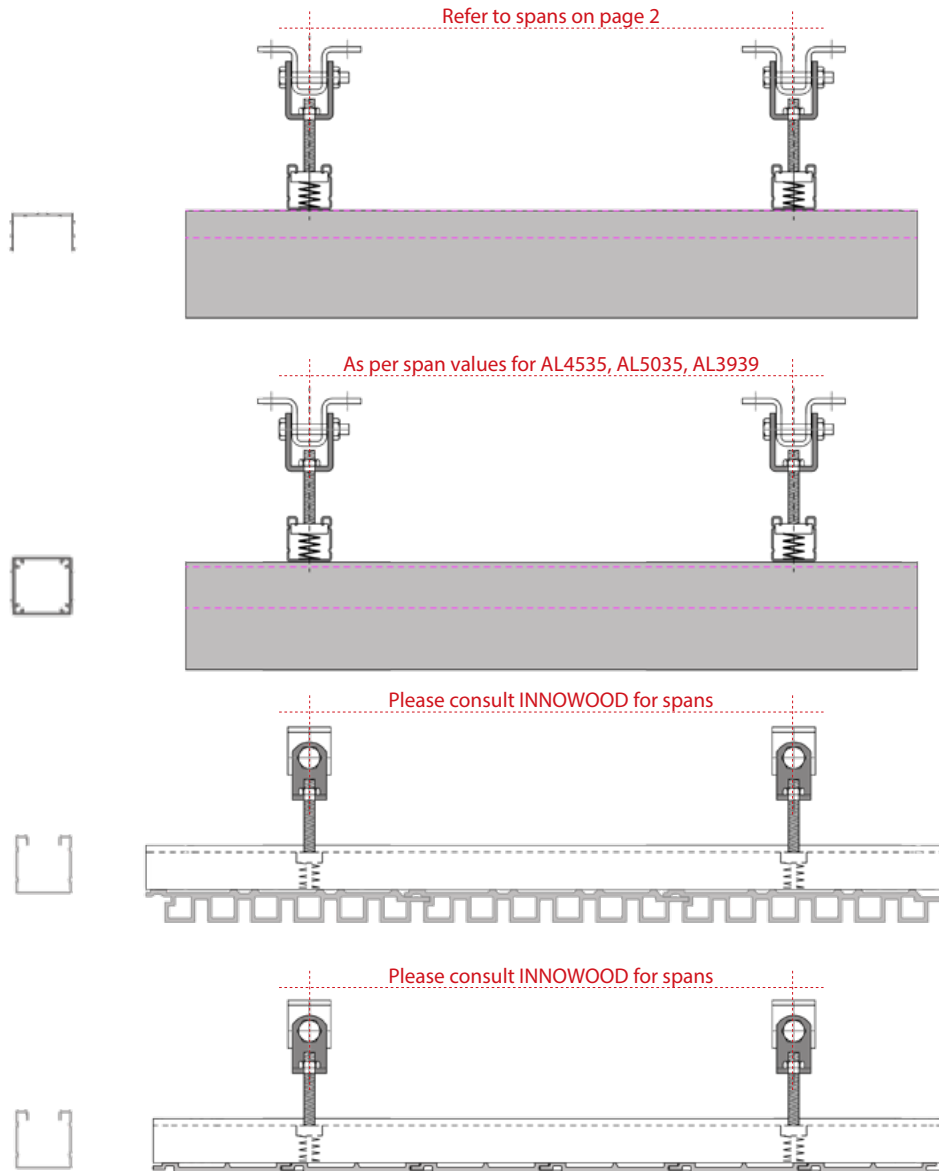

ALTERNATIVE CEILING SYSTEM MEMBERS

Ceiling Connector	
Threaded Rod	
Spring Connector	
Channel Profile	
Channel Profile	

RECOMMENDED SCREW TYPE FOR TIMBER BATTENS

STRUCTURE	Screw Type
Seasoned Timber	#14 bugle bead batten screw with minimum 40mm embedment
Steel Framing	#14-10 x 50mm self drilling hex head (350mm batten) or #14-16 x 65mm self drilling hex head (45mm batten)
Concrete	Ø10 screw in self tapping masonry anchor within min 50mm engagement. Eg. lcons-thunderbolt pro hex head

SUSPENDED CLICK ON FIXING

Please note that the following instruction is also applicable for CL05020/CL07030/CL07030B.

INSTALLATION PROCESS:

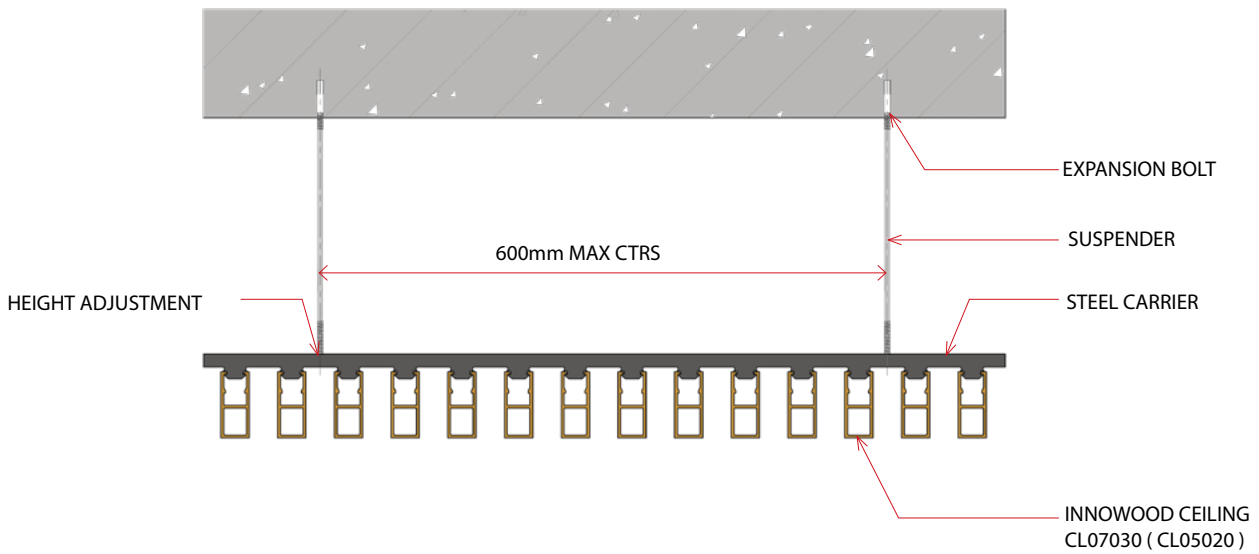

END FINISHES:

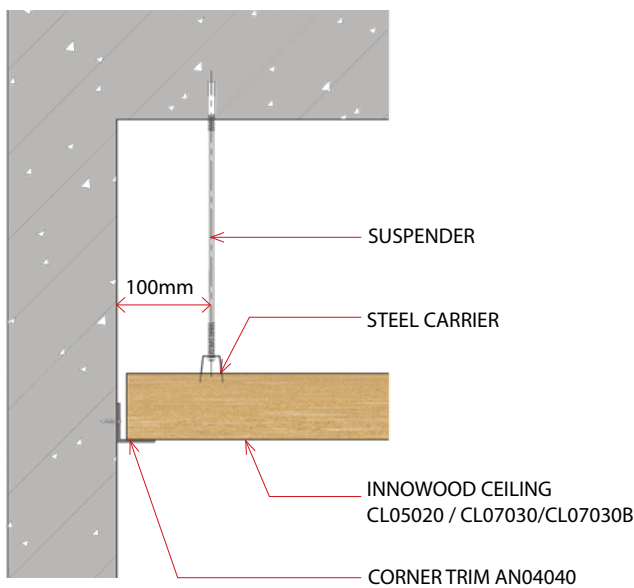

AVAILABLE STEEL CARRIER:

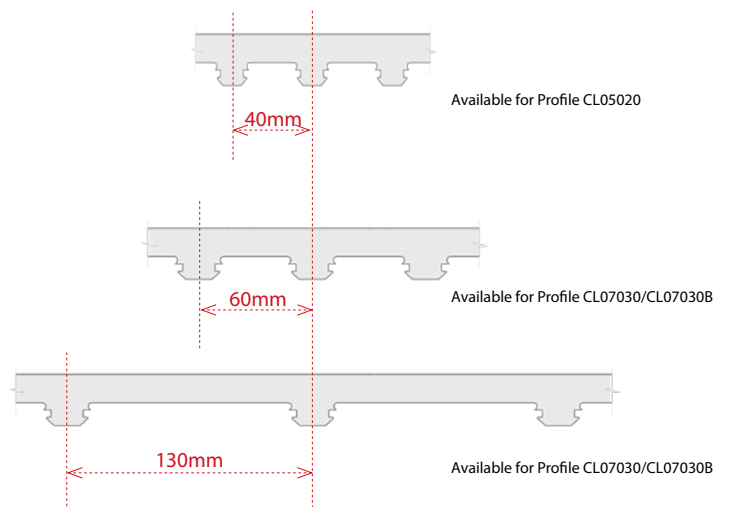

SUSPENDED CLICK ON FIXING

Please note that the following instruction is also applicable for CL05020/CL07030/CL07030B.

①

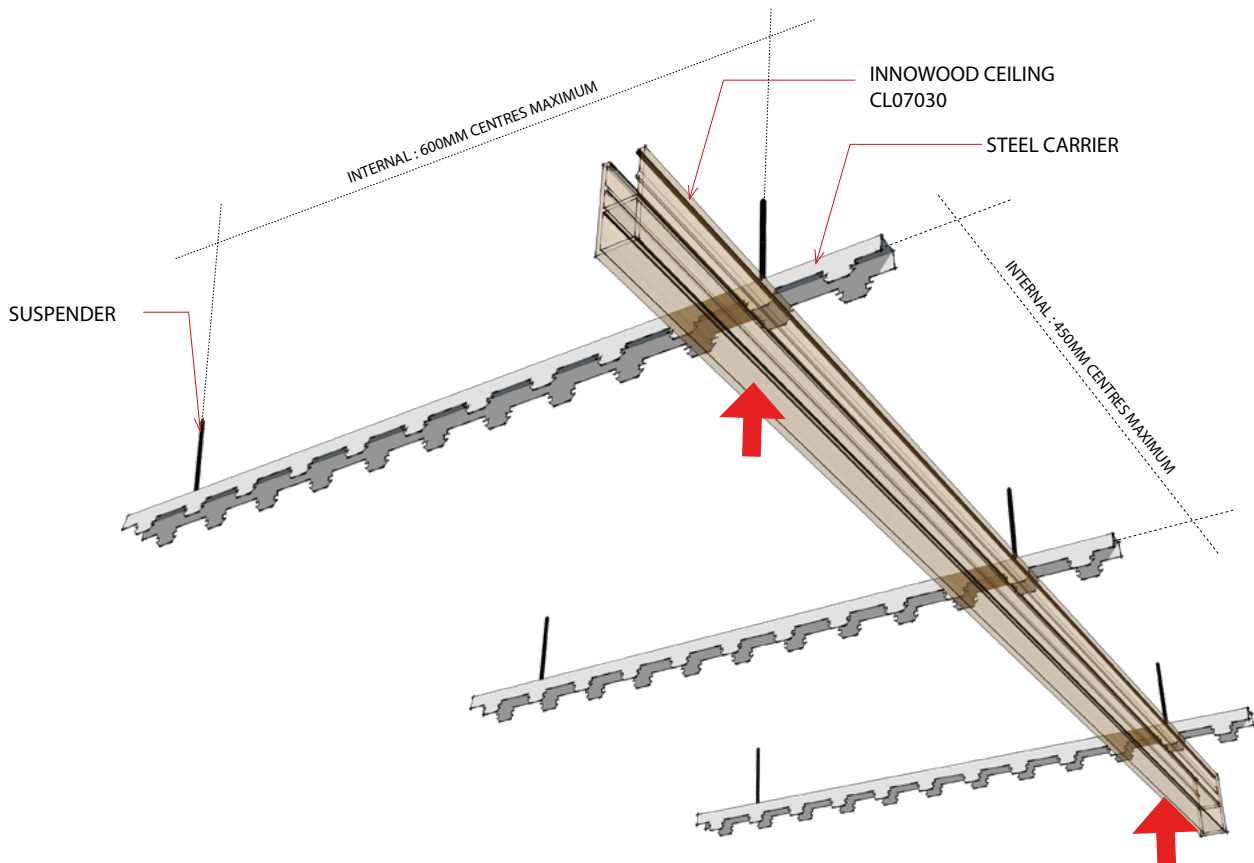

1. Set the height of the ceiling and install the corner trim if required.
2. Install the first row of steel carrier with a distance of 100mm away from the walls. The intervals between 2 rows of carrier are no more than 450mm.
3. Adjust the height of the steel carrier into the same level by adjusting the screws on the suspenders. The intervals between 2 suspenders are no more than 600mm.
4. More carriers or suspender sets will be required if there are cut outs or penetration for downlights, extractors or other electric ceiling products.

SUSPENDED CLICK ON FIXING

Please note that the following instruction is also applicable for CL05020/CL07030/CL7030B.

②

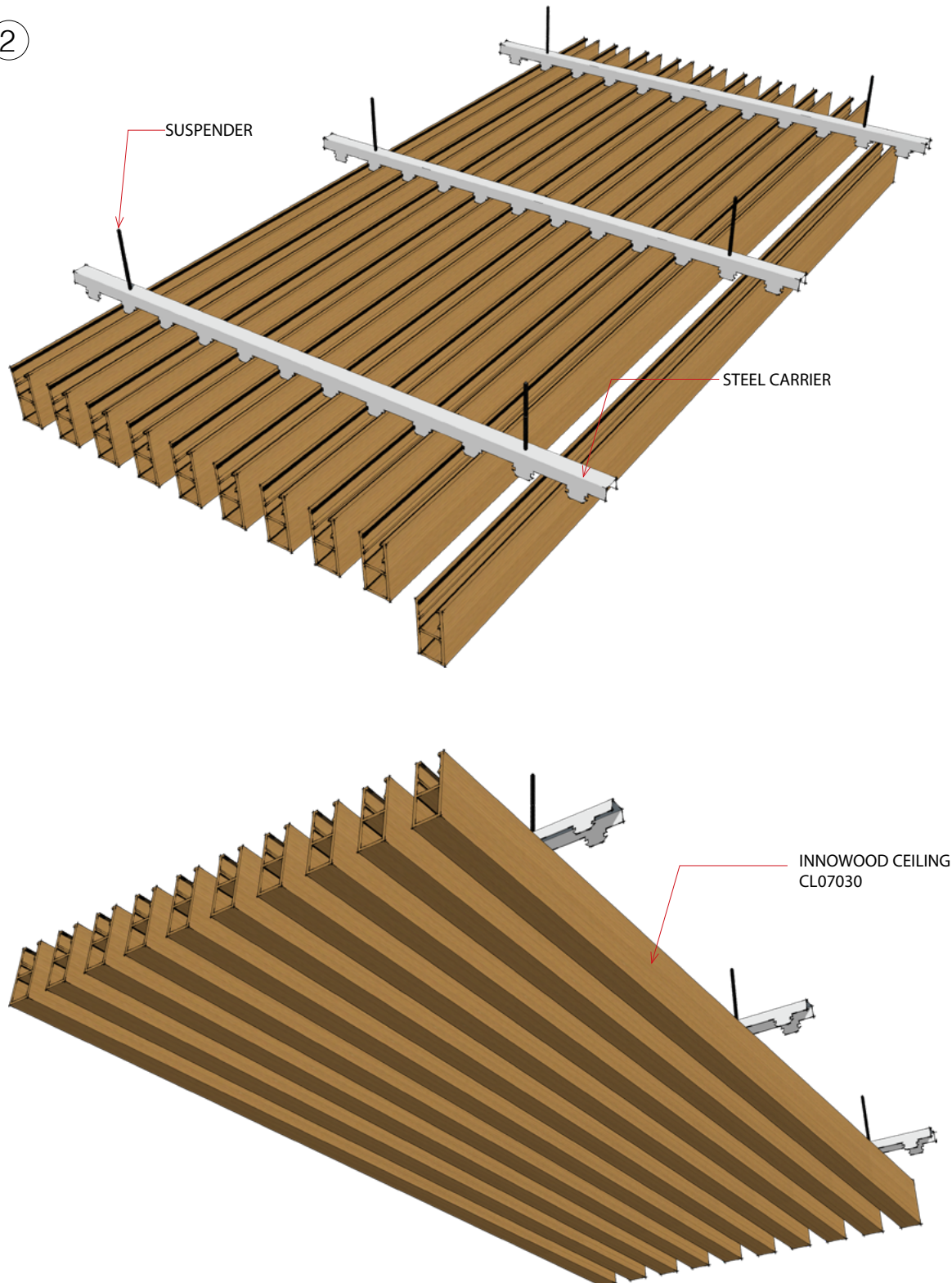

STANDARD MITRED END CAP DETAIL

STEP ①

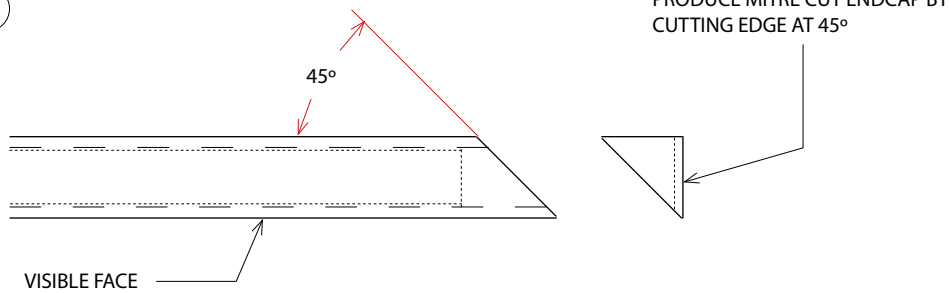

STEP ②

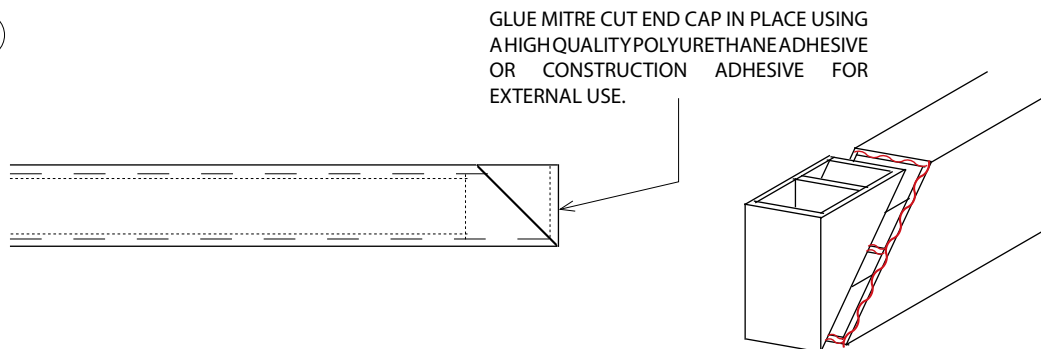

OPTIONAL END CAP DETAIL

OPTION 1:

For normal hollow profiles, glue fix end caps are available.

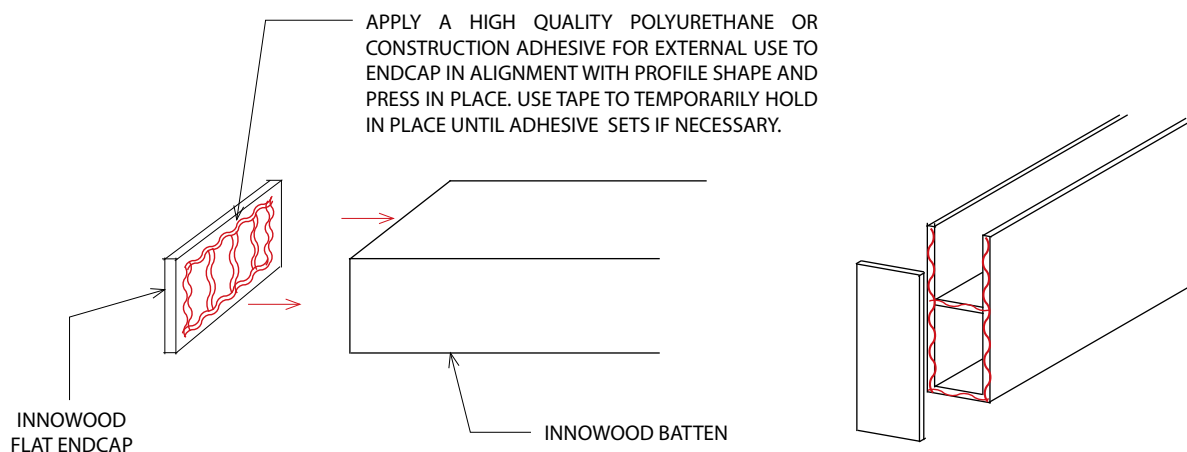

1. Ensure the end of the hollow profile is cleanly cut, dry and free from dust.
2. Apply Sikaflex 11FC epoxy or similar to both mating surfaces, profile and cover piece.
3. Firmly press both surfaces together and wipe away any excess epoxy.
4. Continue to apply pressure until the cover piece is firmly in place.
5. If the cover piece requires slight shaping, carefully sand the square corners as required.
6. Ensure the 4 sides of the cover piece are clean, dry and free from dust.
7. Then carefully apply InnoCoat to the uncoated sides of the cover piece.

EDGE TRIM OPTIONS

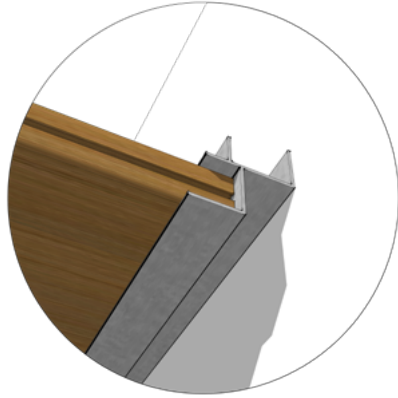

Option of Aluminium Edge Trim

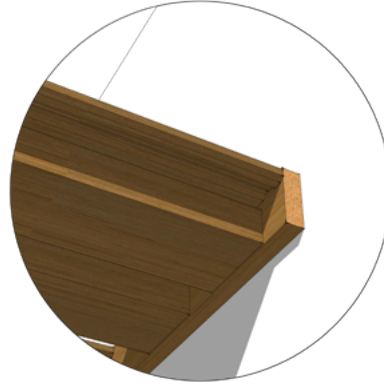

Option of Timber Batten Trim



FOR MORE INFORMATION, PLEASE VISIT INNOWOOD AT
WWW.INNOWOOD.COM
OR CALL 1300 787 717