

IMPORTANT : All INNOWOOD products must be installed in strict accordance with INNOWOOD'S current (at time of installation) "INSTALLATION MANUAL" and "CARE AND MAINTENANCE GUIDELINES" which can be downloaded from our website : www.innowood.com

Failure to comply with these documents may void warranty and result in an unsatisfactory outcome.

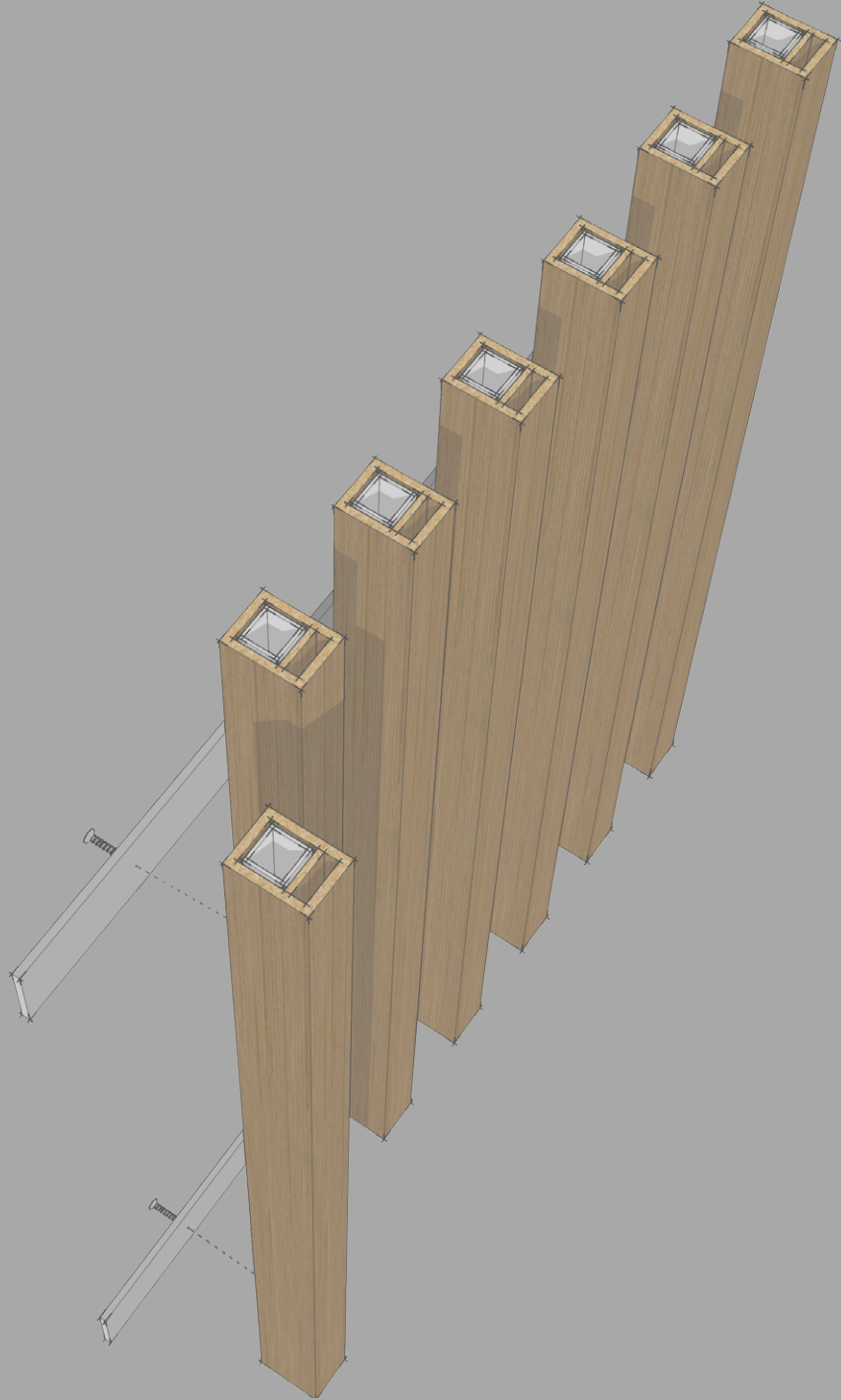

INNOSCREEN

FACE/REAR FIXING
INSTALLATION MANUAL 

BEFORE YOU COMMENCE

Please note that:

The Product is subject to natural variation* in finish as part of the manufacturing process. The purchaser or their installer/builder is responsible for inspecting, prior to installation, the colour, finish and size of the product, identifying whether the Product has any other defect or manufacturing fault, and for ensuring the Product meets surface appearance and product specification requirements. Subject to the terms of our warranty, INNOWOOD is not liable for claims made after the installation of the Product that relate to surface appearance and product specification.

*INNOWOOD product is made predominantly from timber waste, colour will vary up to +/-20% according to the timber used in its manufacture.











It is the responsibility of the specifier or other party to ensure that the information in this manual is appropriate for the intended application and further design detailing may have to be made for specific applications that fall outside the scope of the manual.

Information contained on this document is the copyright of INNOWOOD Australia Pty Ltd. Use or copying of this document in whole or in part without the written permission of INNOWOOD Australia is not permitted.

INNOSCREEN FIXING - PROFILES









INNOVATIVE RANGE:

FACE & REAR FIXING

					
PROFILE SECTION					
PRODUCT CODE	FS04030 / FS04030S	FS06516	FS06020	FS06535	SS05050
COVERAGE	30/40mm	16/65mm	20/60mm	36/65mm	50mm
MAX SPAN WITHOUT ALUMINIUM INSERT *	450mm	450mm	450mm	450mm	450mm

INNOVATIVE RANGE:

FACE & REAR FIXING

				
PROFILE SECTION				
PRODUCT CODE	FS09028	RS10050	FS12530	FS15050
COVERAGE	28/90mm	50/100mm	30/125mm	50/150mm
MAX SPAN WITHOUT ALUMINIUM INSERT *	450mm	450mm	450mm	450mm

*Note - These are for Guidance only and longer or shorter spans may be achieved depending on region and wind load, please confirm with structural engineer prior to installation.

Installation Tips and Requirements

INNOWOOD products can be worked with ordinary woodworking tools such as:

Circular Saw	Cordless Drill
Crosscut Mitre Saw	Level & Chalk Line
Carpenters Square	Tape Measure

Site storage & Product Handling

- INNOWOOD boards should not be stored in the open or covered or wrapped with plastic sheet. INNOWOOD boards are a finished product, do not dump or drop when loading or unloading. Always handle with care.
- INNOWOOD boards should be stored under cover and protected from the elements (including direct sunlight and rain) until ready to install. Remove any plastic wrap including shrink wrap and store on a dry and flat surface supported at max 450mm centres.
- When removing INNOWOOD boards from the pack, do not slide boards against each other, lift the boards and set them down carefully.
- INNOWOOD boards should be carried on their edge for better support.
- When handling INNOWOOD boards take care to avoid scratches, nicks and other damage to the boards.

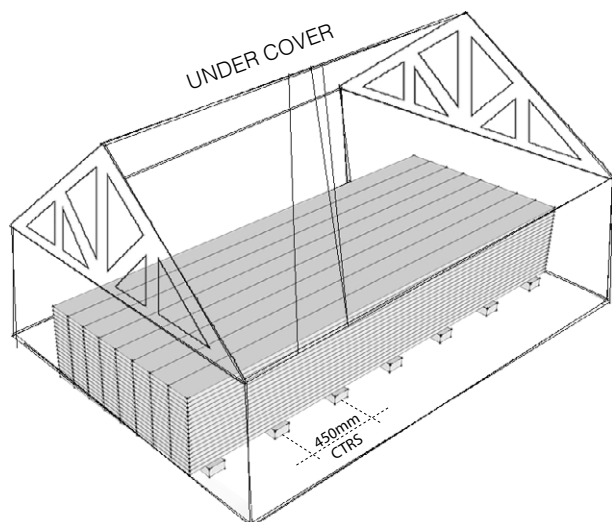

NOTE:

To ensure long-term performance, we recommend that a professional trade person carry out the installation. The installation MUST be carried out in accordance with these instructions including the use of all trims and accessories.

Thermal movement

Any wood based products will expand and contract with changes in temperature. The amount of expansion varies according to the amount of change in temperature. Although thermal movements are reversible, these movements due to temperature change may vary by up to 2mm per meter.

INNOWOOD boards that have been exposed to direct sun for several hours, prior to installation will have expanded more than boards left in the shade. It is important to maintain an average consistent temperature for all boards as they are being installed.

Avoid installing in full sun if ambient temperature is above 30°C. Ensure the boards are kept out of the sun until installed to limit the boards expansion prior to installation. INNOWOOD products can tolerate a temperature range from -20°C to +65°C.

If the product is to be used in an environment outside of this temperature range, please consult INNOWOOD.

Please bear in mind that:

- Where INNOWOOD boards are to be screw fixed, clearance holes must be pre-drilled before fixing (both INNOWOOD boards and accessories).
- The clearance hole to be drilled must be slightly greater than the outside screw thread diameter.
- Screws must be minimum 15mm but maximum 25mm away from board edges (unless noted otherwise)
- INNOWOOD products must not be used for any structural purpose.
- The cut surface must be sealed with a layer of protective coating such as a water based deck sealer before installation.
- When exposed to direct sunlight, surface temperature may be significantly hotter than ambient temperature.





FRAMING CONSTRUCTION REQUIREMENTS



INNOWOOD Screening may be fixed to seasoned timber batten/ top hat or to a proprietary structural system or may be fixed directly to structural substrate such as brick or masonry.

InnoScreen must not be fixed directly to metal cladding as adequate ventilation is required behind screen in this instance. Metal top hats or timber battens must always be used over the top of metal cladding to create a minimum cavity of 35mm.

Fixing spans for INNOWOOD Screening are as per max span figures on page 2 in urban and non-cyclonic wind load areas. Batten/top hat spacing can also be increased by using Aluminium Inserts/Stiffener in certain Screening profiles as per the following table:

Fixing Span with Aluminium Insert / Stiffener Diagram:

	FS04030	FS06020	FS06535	SS05050
Aluminium Inserts/Stiffener Size	19 x 19 x 1.6 Box Section	21 x 9 x 1.6 Channel	50 x 35 Special	39 x 39 x 2 Box Section
Aluminium Inserts/Stiffener Code No.	 AL1919	 AL2109	 AL5035	 AL3939
Fixing Vertically Span Upto	1000mm	600mm	2700mm	2700mm
Fixing Horizontally Span Upto	800mm	600mm	1800mm	2000mm

	RS10050	FS12530	FS15050
Aluminium Inserts/Stiffener Size	39 x 39 x 2 Box Section	19 x 19 x 2 Box Section	39 x 29 Box Section
Aluminium Inserts/Stiffener Code No.	 AL3939	 AL1919	 AL3929
Fixing Vertically Span Upto	2700mm	1000mm	2700mm
Fixing Horizontally Span Upto	2000mm	800mm	1800mm

For higher wind-load areas reducing fixing span may be required.

Each single length of screening must be fixed at minimum 3 fixing points.

As with all screening profile products the adequacy of a proposed installation should always be checked by a qualified engineer.

Timber Support Battens

INNOWOOD screen can be screwed to timber battens provided the following requirements are satisfied:

- When using timber support battens they must have a face width not less than 45mm.
- Timber must be adequately seasoned & deemed for structural use.
- Timber battens must be set at the required centres as per max span figures on page 2 & 4.
- Fixing spans and screw types are shown in the following tables.

BATTEN SCREW TYPE

	SCREW TYPE
Seasoned Timber	#14 bugle head batten screw with minimum 40mm embedment
Steel Framing	#14-10x50 self drilling hex head (35mm batten) or #14-16 x 65mm self drilling hex head (45mm batten)
Concrete	Ø10 screw in self tapping masonry anchor with min 50mm engagement. Eg. Iccons- thunderbolt pro hex head

General Framing Notes

- Battens/Top hats must be true plumb and level to ensure a professional outcome. Packing cannot be used between Battens/Top hats and screen .
- Framing that does not meet all of the criteria in this section will be inadequate and may result in the finished screen showing any of the following characteristics: cupping, bowing, warping, expansion or contraction.

Expansion Joints

Never span InnoScreen across expansion joints in structure. If necessary terminate the screen on either side of any expansion joint to prevent damage to the screen and/or structure.

Adhesive

Where adhesive is mentioned in this manual it must be a high quality polyurethane adhesive (we recommend sikaflex 11FC) or construction adhesive (we recommend selleys liquid nails rapid cure) for external use.

Steel Top Hat Battens

INNOWOOD screen can be screwed to steel top hat battens provided the following requirements are satisfied:

- Top hats must have a face width of no less than 50mm and a wall thickness of no less than 1.15mm.
- Top hats must be set at the required centres as per max span figures on page 2 & 4.
- Top hats must be fixed to structure at the required centres as per the table below and must always be fixed through both legs at all fixing points.

FIXING SPANS FOR TOP HAT

	15 X 50mm	500mm
	24 X 50mm	700mm
	35 X 50mm	800mm
	50 X 50mm	950mm

TOP HAT SCREW TYPES

BACK STRUCTURE TYPE	SCREW TYPE
Seasoned Timber	#12 Type 17 Hex Head Tek screw with minimum 40mm embedment
Steel Framing	#12-14 X 30mm Self drilling Hex head Tek Screw
Concrete	ø6.5 screw in self tapping masonry screw with minimum embedment of 50mm. Eg. Iccons - Grabcon

Screws

Screws must comply with AS 3566 Self Drilling Screws for the Building and Construction Industries.

Screws must have a minimum Class 3 corrosion resistance, suitable for external applications in mild, moderate industrial and marine environments and Class 4 or stainless steel for severe environments.

Screws with class 1 or 2 corrosion resistance may be used for internal use depending on the individual application.

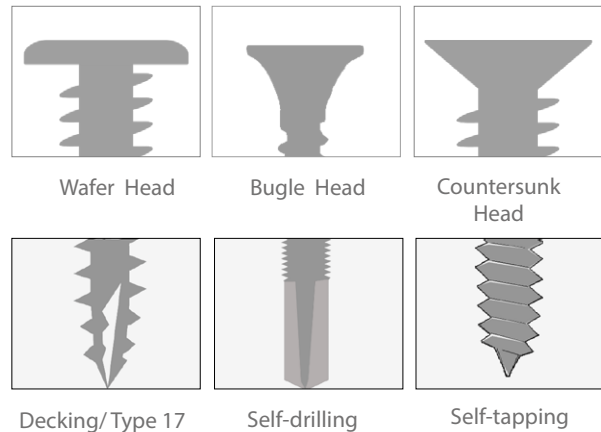

DESIGN CONSIDERATIONS

INSTALLING ABOVE A METAL ROOF -

Metal roofing can add to the heat load of the screen due to UV rays reflecting off the surface which may adversely affect the Innwood product under normal installation conditions. Therefore additional supports must be used to counter this as follows:

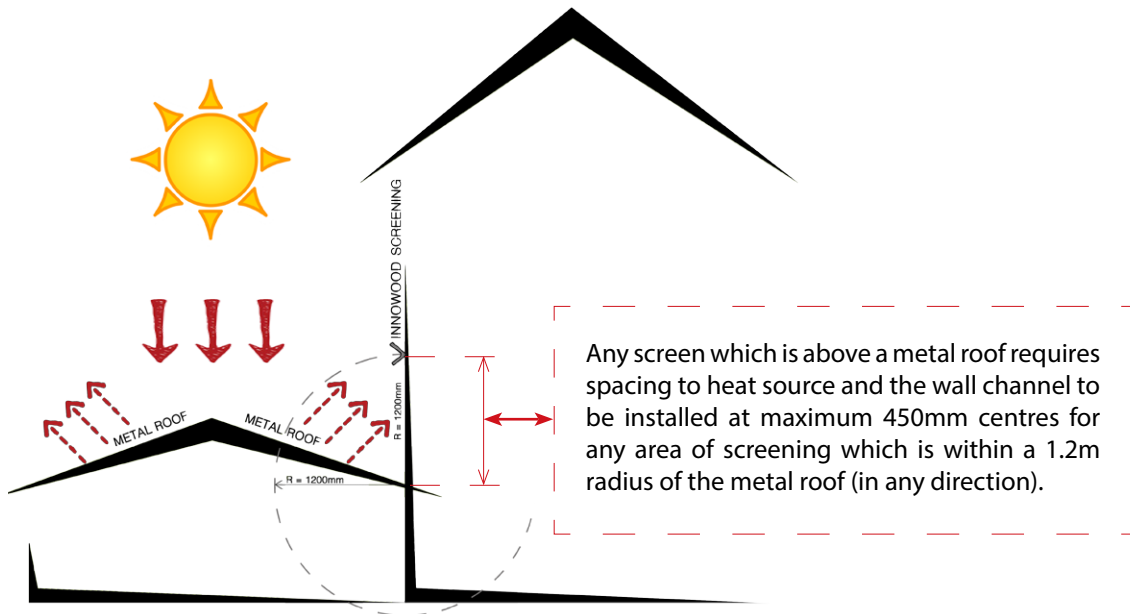

METAL CLADDING -

Innwood screening, when being installed over metal cladding, must require spacing to all cover trims and be installed onto battens or top hats so as to achieve a cavity between Innwood screen and cladding. This spacing and cavity requirement assists in preventing the screen profile from over heating and potentially warping.

Minimum Cavity Size : 35mm

FIBRE CEMENT SHEETING -

Screening may be fixed directly over FC sheeting however the fixings must penetrate through the FC sheeting and into the support framing behind. This should be taken into account when installing FC support framing to ensure the members are situated in the required locations as per this manual.

INSTALLATION PROCEDURE

Please note that this instruction is applicable for the following profiles:

FS04030, FS06020, FS06535, SS05050, RS10050 & FS12530 (hollow profiles can be installed with aluminium inserts to achieve longer fixing span)

FACE/REAR FIXING

①

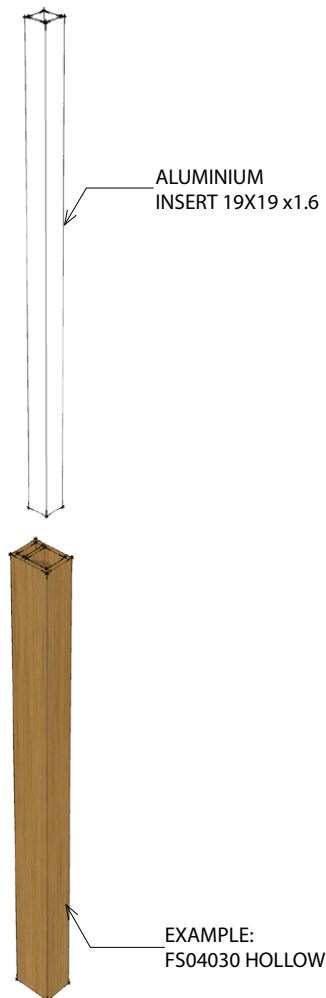

②

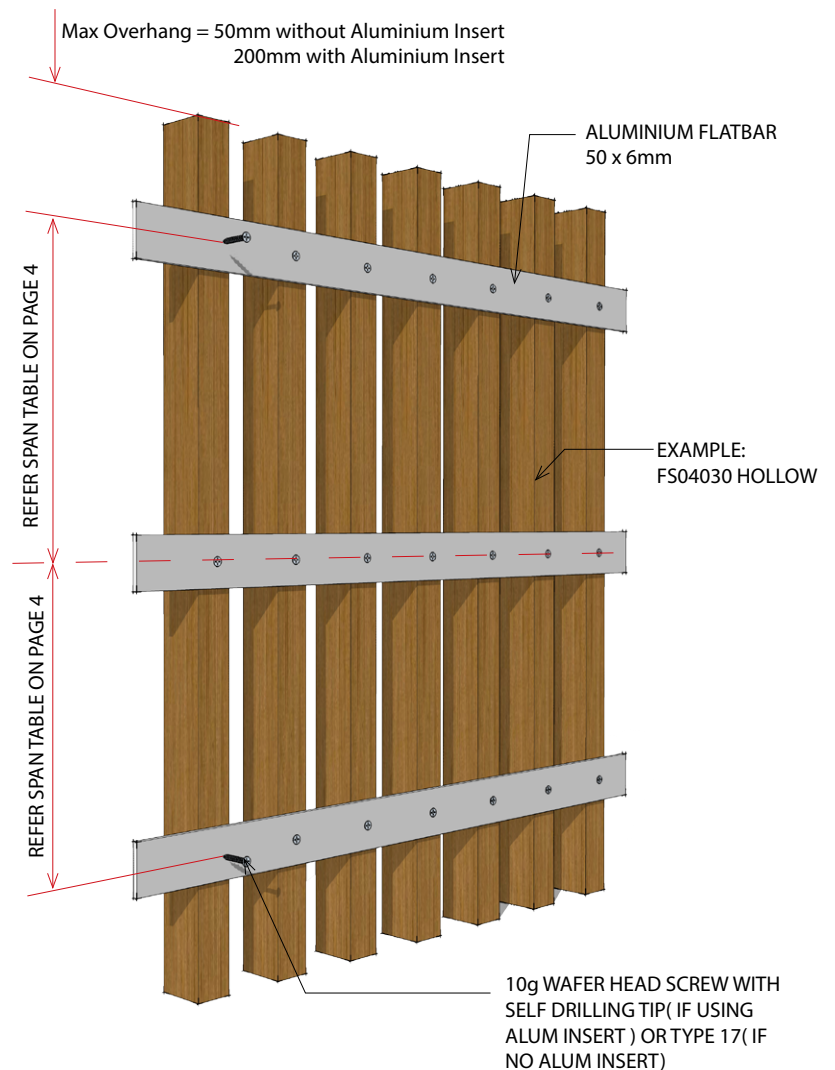

1. Insert the aluminium stiffener into the hollow profile.

Skip this step for solid profile installation, however without aluminium inserts, fixing span should be 450mm.

Note: Aluminium inserts must be 20-30mm shorter than batten at each end.

2. Pre drill clearance holes in the flatbar at the required batten spacing distance. Screw flatbars onto battens to create panels. Fix panels to structure (screw through flatbars) as required.

3. Finish off both ends with end caps if necessary using high quality polyurethane adhesive or construction adhesive for external use.

*Note - These are for Guidance only and longer or shorter spans may be achieved depending on region and wind load, please confirm with structural engineer prior to installation.

TYPICAL FIXING DETAIL - FOR WINDOW & BALCONY PRIVACY SCREEN - WITH LARGE SPAN OPENING

(Applicable for FS06535, SS05050, RS10050 & FS15050.)

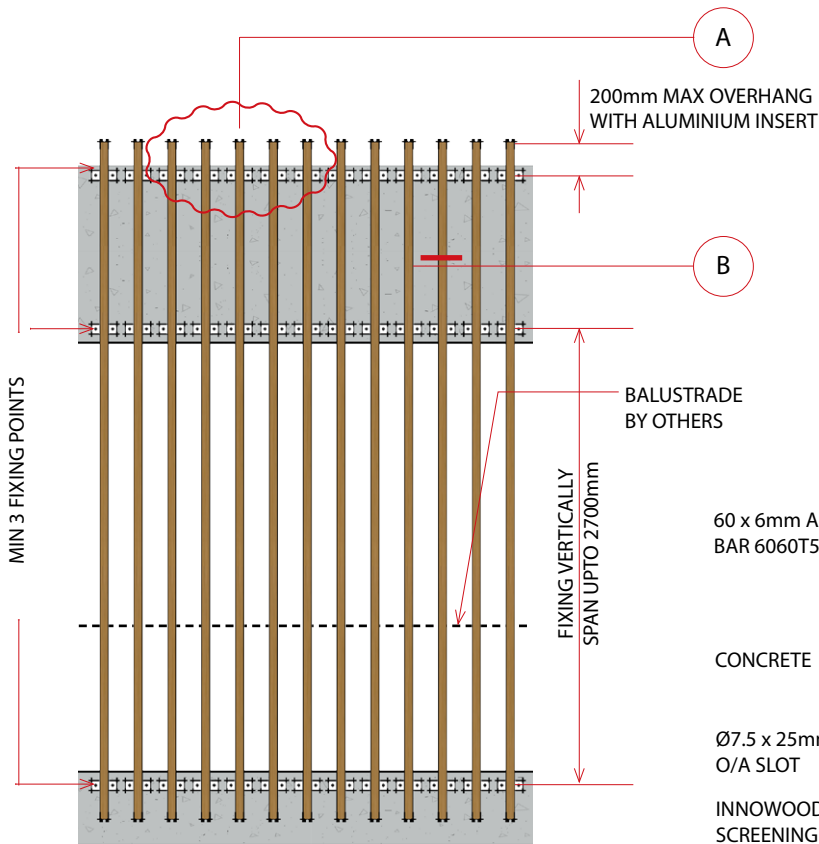

ELEVATION (Reference)

Note: Each single lengths of screening must be fixed at minimum 3 fixing points.

Note:
The design of window and balcony must be in line with the Building Code of Australia (BCA) requirements to prevent fall from heights. Innowood privacy screen should not be used in place of a balustrade or be used as fall protection.

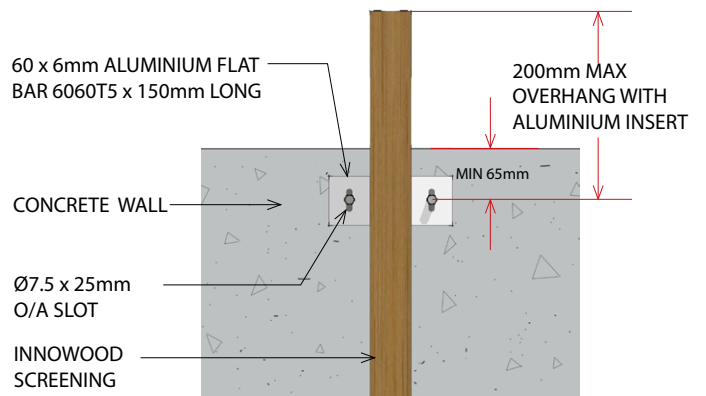

SECTION - A

Option 1 Using FS15050 As Example

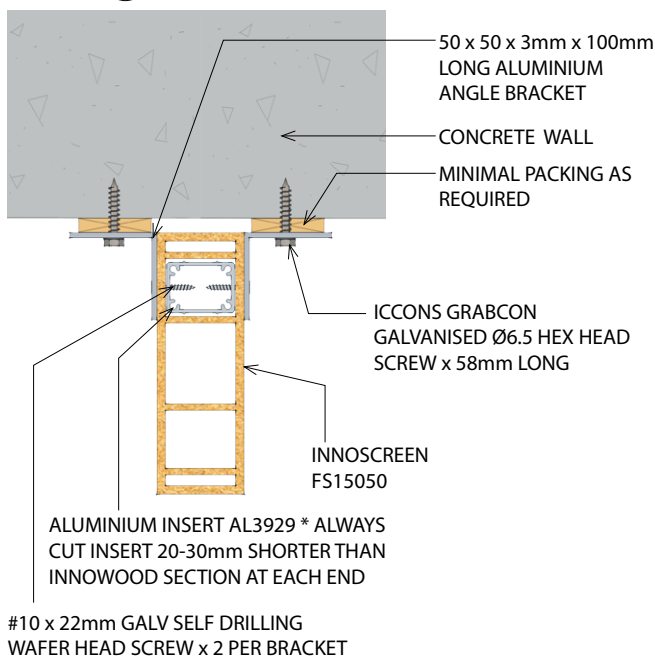

#10 x 22mm GALV SELF DRILLING WAFER HEAD SCREW x 2 PER BRACKET

Option 2 Using FS10050 As Example

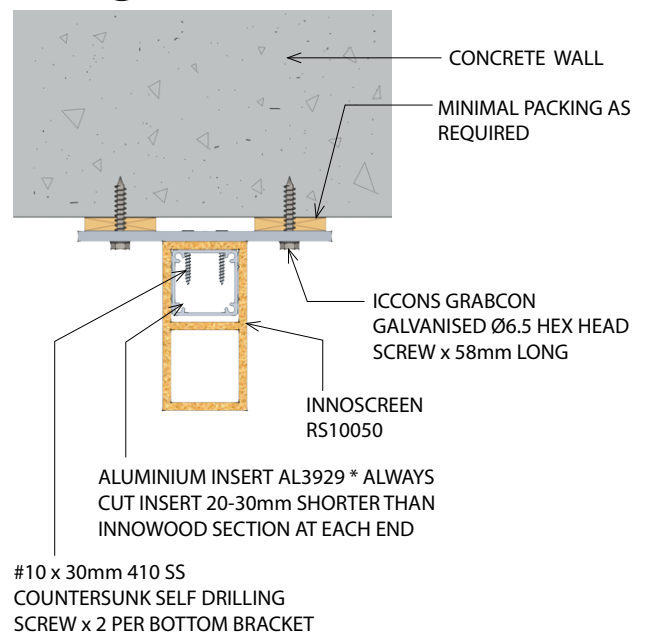

#10 x 30mm 410 SS COUNTERSUNK SELF DRILLING SCREW x 2 PER BOTTOM BRACKET

SECTION - B

BUTT JOINT REQUIREMENTS

2 lengths must not be joined together if there is no aluminium insert and must always be set with a gap as indicated below:

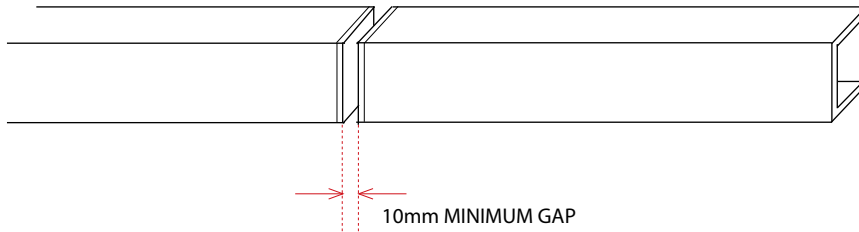

CONTROLLING EXPANSION / CONTRACTION

Face / Rear Fixed Two Side Conditions

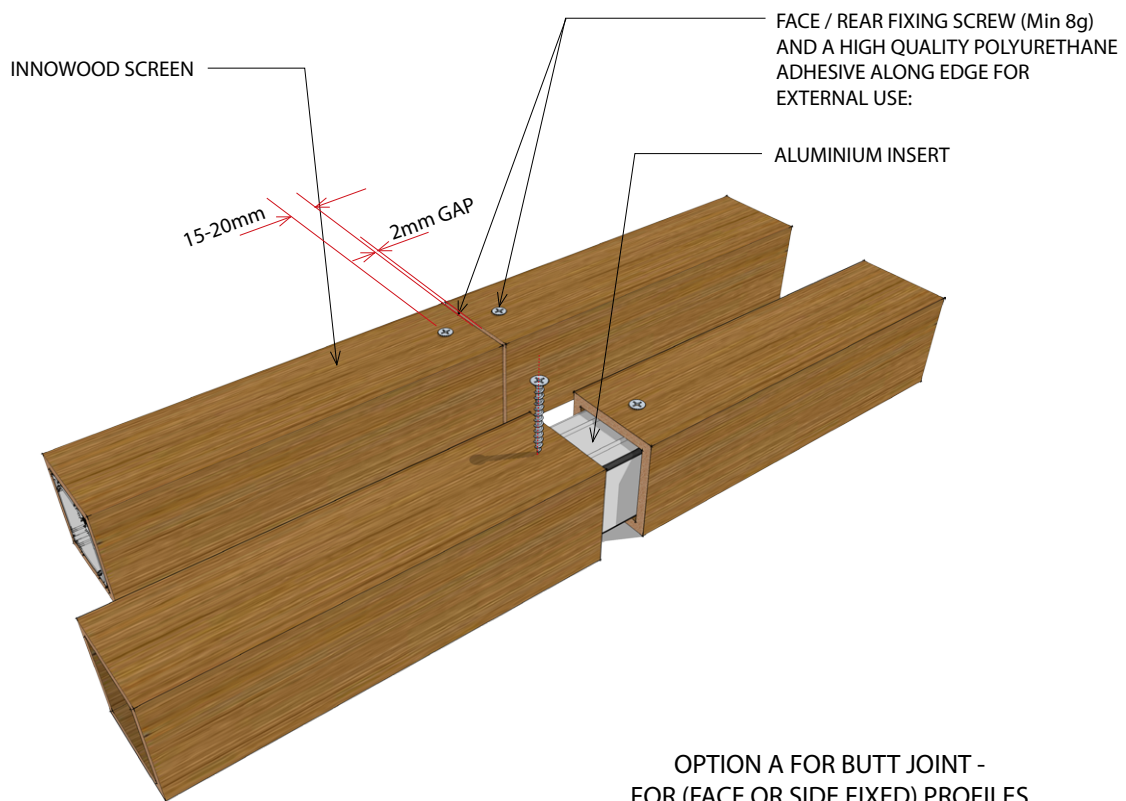

**OPTION A FOR BUTT JOINT -
FOR (FACE OR SIDE FIXED) PROFILES**
FS04030, FS06020, FS06535, SS05050 & RS10050

OPTIONAL MITRE CUT END CAP SOLUTION

STEP ①

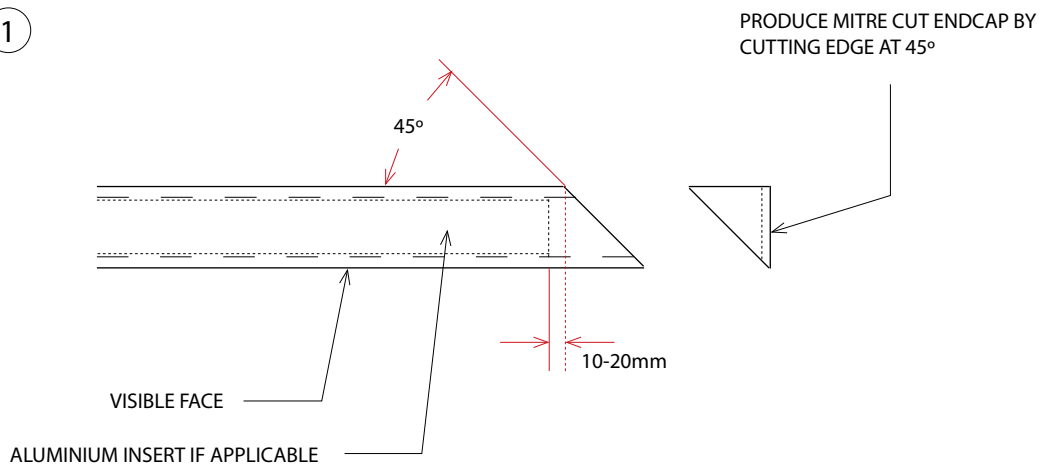

STEP ②

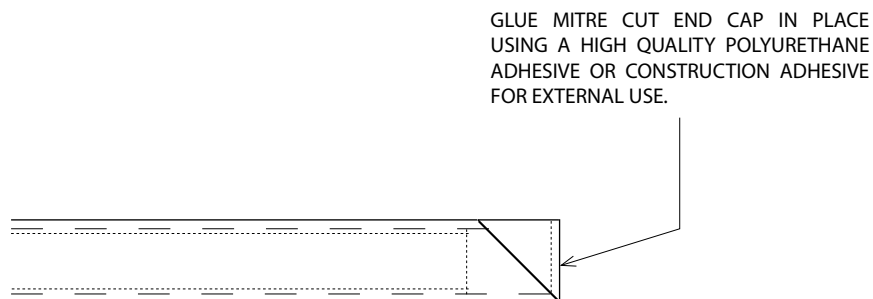

STANDARD END CAP

Instruction for closing off hollow INNOWOOD sections

OPTION 1:

For normal hollow profiles, glue fix end caps are available.

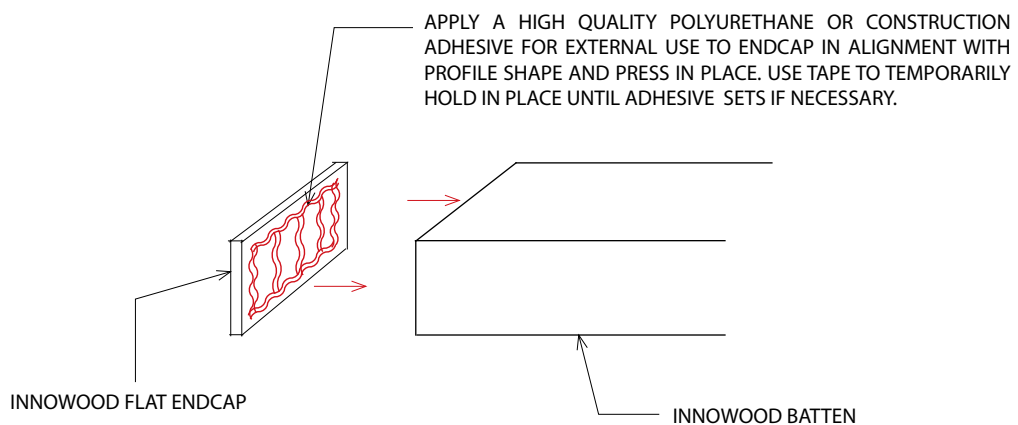

OPTION 2:

The following method uses Aluminium Spigots to create a closed ended section.

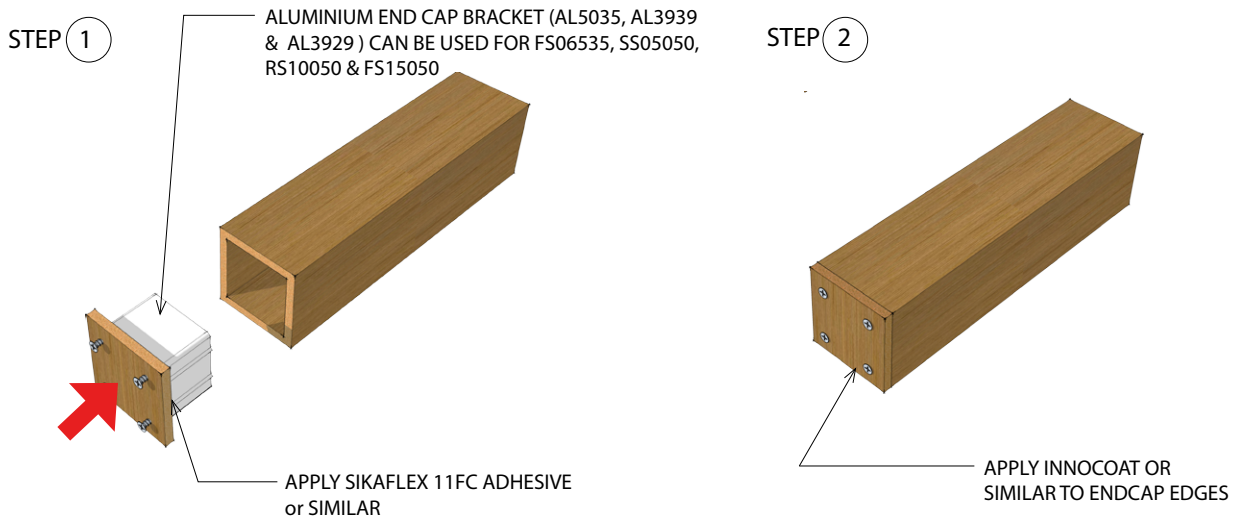

1. Ensure the ends of the hollow profile are cleanly cut, dry and free from dust.
2. Screw fix the Endcap Bracket spigot on to the endcap cover piece as show in fig above.
3. Apply Sikaflex 11FC or similar to both mating surfaces - spigot and inside of batten.
4. Press spigot into batten and wipe away any excess adhesive.
5. Ensure peices are kept in place until adhesive is set.
6. If the cover piece requires slight shaping while set in, carefully sand the square corners as required.
7. Ensure the 4 sides of the cover piece are clean, dry and free from dust.
8. Then carefully apply InnoCoat or similar to the uncoated sides of the cover piece.
9. Similar process can also be used as an option to do a Mitre Cut Corner Joint as shown in the fig below:

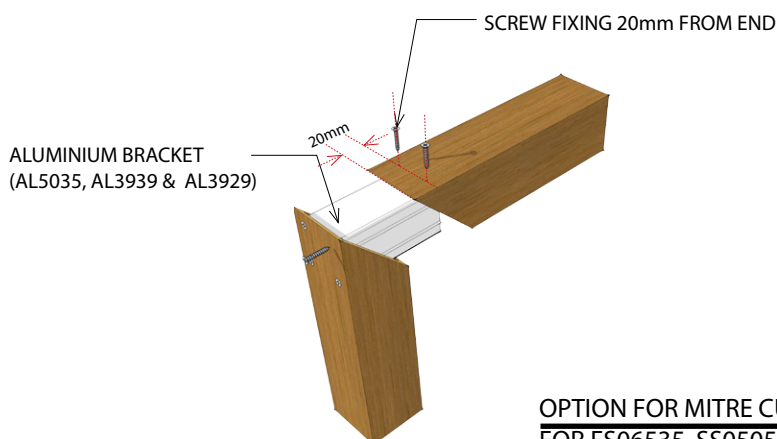

**OPTION FOR MITRE CUT CORNER JOINTS -
FOR FS06535, SS0505, RS10050 & FS15050**



FOR MORE INFORMATION, PLEASE VISIT INNOWOOD AT
WWW.INNOWOOD.COM
OR CALL 1300 787 717